



**BEFORE THE PUBLIC UTILITIES COMMISSION
OF THE STATE OF CALIFORNIA**

Order Instituting Rulemaking Regarding
Transportation Electrification Policy and
Infrastructure.

Rulemaking 23-12-008

FILED

05/21/24

04:59 PM

R2312008

**VEHICLE-GRID INTEGRATION FORUM WORKSHOP REPORT
FILED BY SOUTHERN CALIFORNIA EDISON COMPANY (U 338-E),
SAN DIEGO GAS & ELECTRIC COMPANY (U 902 E), AND
PACIFIC GAS AND ELECTRIC COMPANY (U 39 E)**

REBECCA MEIERS-DE PASTINO

Southern California Edison Company
2244 Walnut Grove Avenue
Rosemead, California 91770
Telephone: (626) 302-6016
E-mail: rebecca.meiers.depastino@sce.com

Attorney for
SOUTHERN CALIFORNIA EDISON
COMPANY

BENJAMIN C. ELLIS

Pacific Gas and Electric Company
300 Lakeside Drive, Suite 210
Oakland, California 94612
Telephone: (415) 265-2678
Facsimile: (415) 973-5520
E-Mail: ben.ellis@pge.com

Attorney for
PACIFIC GAS AND ELECTRIC
COMPANY

WALTER C. WAIDELICH

San Diego Gas & Electric Company
8330 Century Park Court, CP32D
San Diego, California 92123
Telephone: (858) 331-0806
Facsimile: (619) 699-5027
Email: wwaideli@sdge.com

Attorney for:
SAN DIEGO GAS & ELECTRIC
COMPANY

May 21, 2024

**BEFORE THE PUBLIC UTILITIES COMMISSION
OF THE STATE OF CALIFORNIA**

Order Instituting Rulemaking Regarding
Transportation Electrification Policy and
Infrastructure.

Rulemaking 23-12-008

**VEHICLE-GRID INTEGRATION FORUM WORKSHOP REPORT
FILED BY SOUTHERN CALIFORNIA EDISON COMPANY (U 338-E),
SAN DIEGO GAS & ELECTRIC COMPANY (U 902 E), AND
PACIFIC GAS AND ELECTRIC COMPANY (U 39 E)**

Pursuant to Decision (D.) 22-11-040, Ordering Paragraph (OP) 11, issued November 21, 2022, and the *Email Ruling Delaying the Timing of the Vehicle-Grid Integration (VGI) Forums Ordered in D.22-11-040* (Ruling),¹ issued November 13, 2023, Southern California Edison Company (SCE), San Diego Gas & Electric Company (SDG&E), and Pacific Gas and Electric Company (PG&E) (collectively, the “Joint IOUs”)² hereby file the Vehicle-Grid Integration (VGI) Forum Workshop Report (Report), dated May 21, 2024.

D.22-11-040 and the Ruling require that the Joint IOUs shall file the Report and distribute the Report to the service lists for other relevant Commission proceedings.³ The VGI Forum Workshop Report is attached.

Respectfully submitted on behalf of the Joint IOUs,

/s/ Benjamin C. Ellis

Benjamin C. Ellis
Pacific Gas and Electric Company
300 Lakeside Drive, Suite 210
Oakland, California 94612
Telephone: (415) 265-2678
Facsimile: (415) 973-5520
E-Mail: ben.ellis@pge.com

Attorney for
PACIFIC GAS and ELECTRIC COMPANY

Dated: May 21, 2024

¹ See generally Rulemaking (R.) 18-12-006, *Email Ruling Delaying the Timing of the Vehicle-Grid Integration (VGI) Forums Ordered in D.22-11-040* (Ruling) (Nov. 13, 2023) (delayed the VGI Forum until Quarter 1, 2024).

² Pursuant to Commission Rule 1.8(d), counsel for PG&E confirms that SDG&E and SCE have authorized PG&E to file these comments on behalf of the Joint IOUs.

³ Decision (D.) 22-11-040, pp. 231-32 (Nov. 21, 2022); see also Ruling at p. 7.

VEHICLE GRID INTEGRATION FORUM REPORT

Prepared in response to Decision (D.) 22-11-040 by San Diego Gas and Electric Company, Southern California Edison and Pacific Gas and Electric Company

May 21, 2024

Contents

- Executive Summary..... 3
- Background 5
- Part 1 - Ongoing VGI Work Areas at CPUC and CEC..... 6
 - Status of VGI in the California Demand Flexibility OIR 6
 - Interconnection and Distribution Engineering 7
 - High DER Future – Smart Inverter Operationalization Working Group 7
 - CEC Efforts Enabling VGI 8
 - Other Stakeholder Comments 8
- Part 2 - Near-Term Solutions to Support Flexible/Scaled Service Agreements 9
 - IOU Panel 9
 - Industry Panel 12
- Part 3 - Future Procedural Priorities for VGI..... 15
 - IOU Panel 15
 - Industry Panel 16
- Attachment A: Agenda for Forum..... 18
- Attachment B: Presenter Slides 19

Executive Summary

In November 2022, the Commission issued Decision (D.) 22-11-040, which ordered the large-Investor-Owned-Utilities (IOUs), in conjunction with California Public Utilities Commission (CPUC) Energy Division staff, to host an annual vehicle-grid-integration (VGI) forum (VGI Forum) with the objective of convening stakeholders to engage in discussion around the established VGI strategic focus areas of 1) rates and demand flexibility programs; 2) technology enablement and 3) planning¹. The inaugural VGI Forum was held on March 22, 2024, from 9:00 am to 4:30 pm at Pacific Gas and Electric Company's (PG&E) Headquarters located at 300 Lakeside Drive, Oakland CA 94612. Attendees included the IOUs, CPUC Energy Division staff and other regulatory and industry stakeholders. The VGI Forum agenda² comprised of three parts:

- Part 1 - Ongoing VGI Work Areas at CPUC and California Energy Commission (CEC)
- Part 2 - Near-Term Solutions to Support Flexible/Scaled Service Agreements
- Part 3 - Future Procedural Priorities for VGI

The objective of Part 1 was to provide background information on relevant VGI work areas at the CPUC and CEC to provide context and a foundation to facilitate the VGI Forum's forthcoming discussion. Presentation topics included:

- Status of VGI in the California Demand Flexibility OIR
- Interconnection and Distribution Engineering
- High DER Future – Smart Inverter Operationalization Working Group
- CEC Efforts Enabling VGI

Various discussion points were raised by stakeholders such as the emphasis on the importance of programmatic pathways that third-parties can engage customers in to make meaningful contributions to California's seven gigawatt load shift goal by 2023.³ Discussion also addressed the role and interactions between price-based signals and event-based signals that facilitate load management. Notably, the need for prioritization in the case of conflicting signals. Stakeholders also advocated for further development of an alternating current (AC) interconnection pathway to further enable Vehicle-to-Grid (V2G) uses cases for electric vehicles (EVs) with mobile, onboard inverters. Discussion also included the gap in VGI deployment targets and goals from the Commission.

The objective of Part 2 was to engage in discussion on leveraging VGI to enable the flexible or scaled service agreements (Flexible Service Agreement) use case to support customers who are seeking new load but are in a capacity constrained area. Part 2 was comprised of two panels; 1) IOU's experience with implementation of Flexible Service Agreement pilots and 2) Industry's perspective on advancing the Flexible Service Agreement use case. Presentation topics included:

- PG&E's Flex Connect Pilot
- Southern California Edison's (SCE) Load Control Management System Pilot
- Underwriters' Laboratory (UL) 3141 and Power Control Systems

¹ D.22-11-040 p. 172

² Full agenda available in Attachment A

³ <https://www.energy.ca.gov/news/2023-05/california-adopts-goal-make-more-electricity-available-through-smarter-use>

- Enabling and scaling the flexible or scaled service agreements use case

Discussion among the stakeholders highlighted the great potential for the Flexible Service Agreement use case to support timely energization but also recognized the nascency of these efforts, which are currently in a pilot phase of development. The IOUs through their pilot efforts seek to gain the operational experience and lessons learned necessary to inform the scalability and long-term viability of this use case given the current technological, operational, and regulatory unknowns. In addition, the IOUs emphasized the need and priority of ensuring safety as part of implementing this use case. Further, feedback from customers participating in these pilot applications have indicated that customers view the Flexible Service Agreement use case as an interim solution, with the expectation that the IOUs will eventually be able to accommodate the full requested capacity. Stakeholders also highlighted the role of industry in providing inputs to help develop the use case and provide support and service to customers to spur adoption. Stakeholders discussed the maturity and applicability of the UL 3141 standard in enabling the Flexible Service Agreement use case.

The objective of Part 3 was to identify additional priority VGI topics that could be addressed in current proceedings related to Transportation Electrification (TE) Policy, TE Infrastructure or EV Interconnection as well as recommendations for topics to be covered at the next VGI Forum. Part 3 was comprised of two panels; 1) IOU perspective and 2) Industry perspective on emerging issues in interconnection and energization. Presentation topics included:

- Regulatory priorities
- V2G lessons and emerging issues related to interconnection
- Onsite generation to enable energization
- Vehicle-to-Home (V2H) lessons and emerging issues

Stakeholders highlighted the role of VGI in supporting the distribution system, in addition to the transmission system, and discussed the concern about prioritization in the potential case of conflicting signals, such as when both a price and event-based signal is communicated to a customer. Discussion also touched on the role of modeling in addressing fundamental questions related to VGI. Finally, a discussion on the role of equity in VGI and transportation electrification more broadly occurred.

Background

In November 2022, the Commission issued Decision (D.) 22-11-040, which ordered the large-Investor-Owned-Utilities (IOUs), in conjunction with California Public Utilities Commission (CPUC) Energy Division staff, to host an annual vehicle-grid-integration (VGI) forum (VGI Forum) with the objective of convening stakeholders to engage in discussion around the established VGI strategic focus areas of 1) rates and demand flexibility programs; 2) technology enablement and 3) planning.⁴ D.22-11-040 also ordered the large IOUs to file a workshop report within 60 days of the VGI Forum, to capture the discussion and lessons identified for the record of relevant proceedings⁵.

On February 9th, 2024, PG&E served the notice of the inaugural VGI Forum to the service lists of relevant rulemaking proceedings⁶. The VGI Forum was held on March 22, 2024⁷ from 9:00 am to 4:30 pm at PG&E's Headquarters located at 300 Lakeside Drive, Oakland CA 94612. Remote attendance option was also available. Attendees included representatives from the IOUs, CPUC's Energy Division staff and other regulatory and industry stakeholders.

The agenda for the VGI Forum (provided in Attachment A) comprised of three parts:

- Part 1 - Ongoing VGI Work Areas at CPUC and California Energy Commission (CEC)
- Part 2 - Near-Term Solutions to Support Flexible/Scaled Service Agreements
- Part 3 - Future Procedural Priorities for VGI

All presenter slides can be found in Attachment B.

⁴ D.22-11-040 p. 172

⁵ D.22-11-040 OP 11

⁶ R.18-12-006, R.23-12-008, R.22-07-005, R.21-06-017, and R.24-01-018

⁷ Email Ruling dated November 9, 2023, delayed the timing of the VGI Forum ordered in D.22-11-040 from end of 2023 to end of Q1 of 2024.

Part 1 - Ongoing VGI Work Areas at CPUC and CEC

The objective of Part 1 was to provide background information on relevant VGI work areas at the CPUC and CEC to provide context and a foundation to facilitate the VGI Forum’s forthcoming discussion. Audrey Neuman representing Energy Division (ED Staff) provided an introduction to the VGI Forum and the VGI strategic focus areas of; 1) rates and demand flexibility; 2) technology enablement and 3) VGI and planning⁸. Energy Division provided guiding questions for stakeholders to consider throughout the VGI Forum and encouraged stakeholders to focus on identifying “quick-wins” that the Commission could take to address VGI barriers. There was acknowledgment that other critical VGI topics and barriers exists that may require more extensive research and stakeholder discussion, thus not a “quick-win” and not the primary focus of this VGI Forum.

Status of VGI in the California Demand Flexibility OIR

Achintya Madduri representing ED Staff provided a summary and objectives of the ongoing efforts within the Demand Flexibility OIR,⁹ highlighting the crossover to VGI as well as to the CEC’s Load Management Standards. Key questions directed at stakeholders were around the willingness and ability for the VGI ecosystem to adopt and respond to hourly dynamic prices. Affordability was also an important theme with the point being made that demand flexibility can attribute various cost benefits, such as reducing peak loading to mitigate new infrastructure and shifting demand to times of lower wholesale electricity prices. Combined, these examples can ultimately reduce the cost to serve. The Flexible Unified Signal for Energy (CalFUSE) framework was described with examples from Southern California Edison’s CalFUSE pilot. Finally, a high-level timeline of milestones was presented for the implementation of dynamic retail rates.

Stakeholders raised points about the need for programmatic pathways and the role of third-parties in delivering an enhanced customer experience through programs in support of the State’s seven-gigawatt load-shift goal by 2030.¹⁰ The lack of formalized VGI program offerings relative to other jurisdictions outside of California was also noted. ED Staff highlighted issues with affordability and rising rates. As a result, the Commission is taking prudent consideration when assessing pathways that could further contribute to increasing rate pressures. ED Staff noted previous feedback they received from stakeholders on the desire to have dynamic price signals and benefits to the VGI marketplace of exposing components—such as generation, transmission, and distribution—of a dynamic price signal to the marketplace.

Stakeholders also raised the challenge associated with other grid condition, or event-based signals, for example demand response events. The challenge arises when both price signals and event-based signals are communicated to a customer, and it is not clear to which signal the automated dispatch logic should respond or prioritize. While different types of signals may be needed to address different needs, the translation of multiple signals, especially if they may conflict, poses challenges.

⁸ Three strategic focus areas were identified in D.22-11-040

⁹ R.22-07-005

¹⁰ <https://www.energy.ca.gov/news/2023-05/california-adopts-goal-make-more-electricity-available-through-smarter-use>

Interconnection and Distribution Engineering

Eric Martinot representing ED Staff provided a regulatory overview of the various Decisions, Advice Letters and Reports relevant to electric vehicle interconnection under Electric Rule 21. An overview of the current landscape of electric vehicle supply equipment (EVSE) interconnection pathways for V1G, V2G and V2H was provided with an emphasis on identifying which interconnection pathways either; 1) formally exist and are covered under Electric Rule 21; 2) exist only in pilot phase or are part of ongoing discussions and 3) do not exist. Additional detail for V1G, V2G, and V2H interconnection pathways were provided illustratively and can be found in Attachment B.

Stakeholders highlighted the importance of further consideration and development of the V2G Alternating Current (AC) interconnection pathway. Most of the work in V2G has been with Direct Current (DC) to date, but stakeholders pointed out the potential equipment and installation costs savings of an AC implementation which could spur increased adoption of V2G. Standards development for AC such as UL 1741-SC¹¹ and UL 1741 QIKP¹² were referenced as ongoing efforts. Additionally, stakeholders highlighted the grid-connected or grid-parallel V2G use case and the need for more focused effort on this use case since it has potential to scale and make more commonplace the V2H use case, beyond grid outage situations.

High DER Future – Smart Inverter Operationalization Working Group

Raymond Breault representing ED Staff provided background on the Smart Inverter Operationalization Working Group (SIOWG) and highlighted key findings from the recent SIOWG Report.¹³ The concept of operational flexibility to optimize the use of existing capacity while maintaining grid safety and reliability was highlighted as a topmost priority identified by the SIOWG in order to support a high distributed energy resource future. The concepts of Firm Export/Import Limits of Power, Non-Firm Export/Import Capacity, Minimum Export/Import Requirement and Command Export/Import were presented as key concepts to operational flexibility. More specifically to EVs, the SIOWG identified Business Case E (Operational Flexibility for EVs Providing Distribution Services) along with various use cases which address how EVs can provide distribution grid services. Challenges presented included:

- 1) The ability for Power Control System (PCS) to reliably enforce site import or export limits.
- 2) The need for increasingly granular and dynamic schedules or commands.
- 3) The regulations and tariffs necessary to support operational flexibility.

Finally, a high-level timeline of milestones was presented leading up to a Proposed Decision within the High DER rulemaking proceeding (R.21-06-017).

¹¹ Underwriters Laboratories (UL) 1741 Supplement SC is a certification for bidirectional EV supply equipment and interconnection systems equipment for EVs with bidirectional onboard inverters.

¹² Underwriters Laboratories (UL) 1741 QIKP is a certification for bidirectional EV supply equipment.

¹³ Under Track 3 Phase 1 of High DER OIR (R.21-06-017)

Stakeholders cited questions and concerns regarding the various communication protocols that are under discussion to date, including OCPP¹⁴, ISO 15118¹⁵ and IEEE 2030.5¹⁶. Discussions acknowledged the various protocols and also that given the nascency of DERMS, it is not clear which protocols will prevail. Ongoing, initial implementations of DERMS use cases will test and provide the lessons learned to inform any requirements going forward.

CEC Efforts Enabling VGI

Jeffrey Lu representing the CEC presented on the ongoing VGI efforts at the CEC. The CEC has four general categories of VGI efforts; 1) technology funding, 2) regulations and programs, 3) analysis and reporting and 4) standards support. High-level workstreams under each category were described, including recent and upcoming grant-funding-opportunities related to VGI to support a diverse scope of VGI use cases and projects.

Stakeholders cautioned that funding for technology research and development (R&D) may have an unintended consequence of hampering innovation if the scope is too narrow. The market will direct their focus to meet the requirements to receive funding, potentially missing other opportunities. ED and CEC staff acknowledged, that within innovation, there are many possible areas that warrant R&D, but staff cannot have expertise in them all. Instead, their role is more so to reduce barriers to foster an ecosystem conducive to innovation.

Other Stakeholder Comments

Stakeholders noted a gap in discussions around the setting of targets and goals for VGI deployment and whether there was interest from the Commission in establishing targets and goals. In response, ED staff acknowledged that establishing accurate targets poses a challenge due to the uncertainties regarding market direction and that further evaluation would be needed in order to develop well informed targets and goals. As a partial solution, minimum enrollment or participation targets are implemented as part of some demand flexibility pilots and transportation electrification infrastructure programs.

¹⁴ Open Charge Point Protocol (OCPP) is an application protocol for communication between EV charging stations and a central management system, also known as a charging station network.

¹⁵ International Organization for Standardization (ISO) 15118 is a standard that specifies the communication between the EV and EVSE.

¹⁶ Institute of Electrical and Electronics Engineers (IEEE) 2030.5 is a standard protocol for communications to enable utility management of the end user energy environment, including demand response, load control, time-of-day pricing, management of distributed generation, electric vehicles, etc.

Part 2 - Near-Term Solutions to Support Flexible/Scaled Service Agreements

The objective of Part 2 was to discuss technical and regulatory barriers related to leveraging VGI technology to enable advancement of the flexible or scaled service agreements (Flexible Service Agreement) use case as well as identifying potential quick-wins to address the identified barriers. Part 2 was comprised of two panels; 1) the IOU's experience with implementation of Flexible Service Agreement pilots and 2) Industry's perspective on advancing the Flexible Service Agreement use case.

IOU Panel

Neema Yazdi and Alex Portilla representing PG&E introduced PG&E's Flexible Service Agreement concept (Flex Connect) which aims to provide customers seeking energization in a capacity constrained area a bridge solution by communicating dynamic operating limits to local energy management systems. Having the ability to be responsive to dynamic import limits allows a customer who might otherwise be denied their full energization request to proceed. The benefits of Flex Connect was illustrated using a real-world example where a customer under the status quo planning scenario would not have been able to energize at their requested capacity amount. By participating in the Pilot, the example customer could receive their full requested capacity amount a majority of the time and only need to be limited during specific hours during the Summer season. PG&E shared they have begun offering Flex Connect to customers with near-term goals of standardizing the customer engagement and site evaluation process. A communications line diagram for an illustrative site was also shared to discuss the technical aspects and integrations involved in Flex Connect, such as the IEEE 2030.5 communication protocol between PG&E's Distributed Energy Resource Management System (DERMS) and the customer's site control system. Finally, PG&E raised key customer and utility considerations in implementing Flex Connect.

Key Customer Considerations

- Customers do incur the costs associated with having load control technology installed at their site to ensure they are able to be responsive to dynamic limits. The scale and costs are in part dependent on the current site and equipment readiness for communication and load management. The customer must make the judgement whether the incremental value they receive in terms of additional capacity, justifies the cost and operational complexity of the system.
- Load-limiting during times when the full requested capacity cannot be provided has potential impact on customer experience and depending on the customer's operational needs, this type of load flexibility may or may not be possible.

Key Utility Considerations

- A DERMS needs to be in place with capabilities to forecast grid conditions and dispatch accordingly. The DERMS also needs to be integrated with third-party or customer systems to ensure dispatch instructions are delivered.
- Confidence in the customer's load control solution is needed to ensure safe operations of the grid. This includes having appropriate fail safes and contingency plans when the primary solution fails (e.g. loss of communications).

- Determine customer acceptance of Flex Connect as an interim solution where a customer will be limited during a period of time when their full capacity request is provided or if this is a longer-term solution where the customer's load is limited in perpetuity.
- To scale Flex Connect, a policy discussion is needed to determine the appropriate methodology to apportion scarce capacity across multiple customers during times of constraint. It is more straightforward to allocate the available capacity for a given circuit when there is only a single participating customer, but when multiple customers on the same circuit are participating in Flex Connect, that implicates a need for a methodology to equitably share the available capacity.

Roger Salas representing Southern California Edison (SCE) presented on SCE's Load Control Management System (LCMS) Pilot. Similar to PG&E, LCMS was presented as a bridge solution which mitigates long lead times associated with capacity upgrades by allowing customers who can do automated load management (ALM) to energize. Challenges to implementation of LCMS were grouped into the categories of technology, operations and legal or regulatory challenges.

Technology Challenges

There are no national standards for testing and certifying ALM equipment for the Flexible Service Agreement use case. Development of UL 3141 is in progress, but until it is finalized the IOUs will have to enforce their own requirements to ensure safety.

Operational Challenges

Operating the grid is highly complex with established and well-defined procedures. The introduction of LCMS introduces a new variable for grid operators to consider and as a result, new procedures need to be developed to operationalize and integrate into grid operations. These procedures must include contingency measures in the event LCMS fails.

Legal or Regulatory Challenges

There are no established regulatory procedures to govern the use of LCMS technology or PCS within distribution planning and operations. SCE's LCMS Pilot was approved on a pilot basis via Advice Letter 5183-E/E-A.¹⁷

SCE presented on their LCMS Pilot which consists of a *Local Autonomous* pathway and *Communications-Based* pathway. The *Local Autonomous* pathway is currently in deployment and involves installation of customer-owned load control technology at the site. SCE reviews and approves the technical specifications and tests performance of the load control technology. SCE then develops the load profiles which the site must maintain. The customer is responsible for ensuring the load profile is respected and SCE can monitor the sites performance to ensure compliance. SCE is currently discussing the *Communications-Based* pathway with a potential participant. The *Communications-Based* pathway involves SCE's Advanced Distribution Management System (ADMS) which is able to determine site limits dynamically based on grid conditions and send those limits to the customer's communication interface via IEEE 2030.5 protocol. Finally, SCE provided a high-level timeline of their LCMS Pilot.

¹⁷ On January 16, 2023, SCE Advice 5138-E/E-A was approved by Energy Division with an effective date of January 3, 2023.

Danielle Weizman representing San Diego Gas & Electric Company (SDG&E) reiterated key themes and takeaways from the IOUs.

- The Flexible Service Agreement use case, such as those presented by PG&E and SCE, can be mutually beneficial in the instances where grid capacity is so delayed that significant and lengthy upgrades are necessary to enable a full level of service to the customer. In these circumstances, flexible solutions can be beneficial for both the customer and the utility. Utilities can increase throughput across their distribution system infrastructure, optimizing the use of existing infrastructure to serve customers in a timely manner.
- SDG&E has not seen a need for this specific solution in its service territory because of how they work with customers to find mutually agreeable service designs and timelines, including phasing buildout. However, SDG&E is continuing to monitor these pilots and ongoing trends in its service territory.
- Customers may mitigate long lead times associated with grid upgrades by utilizing a bridge solution that allows them to receive their full capacity request for a given circuit at certain off-peak times in exchange for curtailment at on-peak times. There are costs incurred by the customer to implement ALM, so the value proposition may vary from customer to customer depending on their own operational needs and capabilities.
- The capabilities of DERMS, ADMS or other utility grid management systems to actively communicate with, monitor, and control DERs will be critical to the successful scaling of this use case, but its capabilities to support this use case are still nascent to date. Within the crawl, walk, run framework, the IOUs are still early in the crawl stage with their respective pilot efforts.

ED staff asked the IOUs what information would be helpful from industry to inform the optimal approach to scale the Flexible Service Agreement use case given the various approaches that were presented. The IOUs reiterated key points related to ensuring safety in grid operations and the nascency of the pilots. The Flexible Service Agreement use case ultimately relies on customer owned equipment, and in conjunction with technology vendors or third-party service providers, must ensure limits are respected. The IOUs emphasized the need for operational experience to build the confidence and assurance for grid operators that the customer-owned equipment can perform reliably with fail safe measures in place should they be needed. The IOUs also raised the uncertainty around customer willingness to adopt this solution, citing that initial feedback from customers participating or interested in participating see this as an interim solution where the utility will eventually build the full capacity requested.

Flexible Service Agreement is a paradigm shift in terms of customer expectations as it relates to energization and the utility's obligation to serve. Traditionally, customers have expected the utility to accommodate their full requested capacity at all times. However, the Flexible Service Agreement use case is not only counter to this but also creates new obligations for the customer. Industry has a big role in terms of supporting customers by providing guidance and subject matter expertise to help inform customers on whether the value proposition exists for them based on their operational needs. Load-limiting may not align with the customer's operational needs in certain cases and there may be certain load profiles that are not conducive to the Flexible Service Agreement use case (e.g. flatter, less peaky load), so customers need to make informed decisions on whether this offering is appropriate for them.

A similar question was asked to the IOUs regarding what is needed from the Commission to further advance and scale the Flexible Service Agreement use case. The IOUs emphasized the overall theme of needing to be nimble and responsive, given the unknowns that exist. Streamlined Commission review and approval process would enable the IOUs to take the learnings from the IOUs initial pilot efforts and operationalize what does work and adjust what does not work. Development of a common framework that stakeholders can use to coordinate across the multiple proceedings that implicate VGI, and other DERs more broadly, would be helpful to ensure alignment on the higher-level goals and objectives. For example, the framework could speak to a methodology to allocate scarce capacity across multiple customers who may be participating in Flexible Service Agreement, or a regulatory pathway to seek requests for new or modifications to Flexible Service Agreement efforts, as well as when cost recovery is or is not appropriate.

Stakeholders inquired about the IOUs characterization of the Flexible Service Agreement use case as a bridge solution and questioned whether it could also serve as a longer-term solution given the scale and pace of transportation electrification. The IOUs view it as a bridge solution at this nascent stage, but acknowledge that it will be primarily driven by the market, customer preferences and available grid capacity. The ultimate goal is to provide customers with their full requested capacity, so presumably the Flexible Service Agreement use case would no longer be needed for a customer after upgrades have been completed. For customers that are willing and able to treat Flexible Service Agreement as a longer-term solution, that could be an option. Separately, there was general consensus among stakeholders, including the IOUs, that for the longer term, a standardized offering such as Flexible Service Agreement will likely be a need to accommodate transportation electrification growth.

Industry Panel

Marc Monbouquette representing Enphase Energy presented on the barriers and regulatory needs to be addressed in order to further enable and scale the use of PCS in enabling the Flexible Service Agreement use case. While options for PCS use are explicitly included in Electric Rule 21, it is notably absent in the other Electric Rules pertaining to service or distribution infrastructure – such as Electric Rule 2, 3, 15, 16 and 29/45. As a result, industry is unable to fully realize the benefits of PCS capabilities. The new UL 3141 standard was published in January 2024 and covers PCS functionality. The first version of UL 3141 includes test protocols for Power Export Limiting (PEL) and Power Import Limiting (PIL) at the device level. The second version is currently under development and intends to develop protocols for PIL at the point of common coupling. The need for clear language recognizing UL 3141-certified PIL was cited as a need for the Flexible Service Agreement use case. While UL 3141 is still under development, the precedent from Rule 21 and the Smart Inverter Working group to adopt forthcoming standards was cited to future-proof the relevant Electric Rules prior to the finalization of the standard. In addition to standards, other factors that inhibit the adoption of the Flexible Service Agreement use case are the lack of standardized tariff provisions and forms, such as terms and conditions. As such, customer and project developers lack awareness of this offering. The lack of technical product requirements also does not provide technology providers the direction needed for product development.

Enphase provided the following procedural recommendations:

- Build on the SIOWG Report in Track 3 of the High DER proceeding avoiding duplication across the relevant proceedings¹⁸ to ensure a consistent implementation and mitigate inconsistencies.
- A new scoping memo in Track 3 of the High DER proceeding to initiate revisions to the IOUs relevant Electric Rules to incorporate UL 3141, PCS, and Flexible Service Agreement options.

Jacqueline Piero representing The Mobility House provided a comparison of implementation considerations between static site limits and flexible connections. The need for Commission action to adopt UL 3141 was reiterated as necessary to clear the standards ambiguity as there have been various other standards that have either been considered or accepted for EV load control by industry. Multiple regulatory development considerations were presented:

- Accessibility of the Flexible Service Agreement use case should be preserved for utilities of varying technical resources, meaning having options such as static limits in addition to supporting dynamic limits.
- Requirements for day one implementation must include availability of contracts, an understanding of the customer journey and assessment criteria.
 - Including the study methodology and site criteria to evaluate whether customer is a good candidate for Flex/Scaled Service Agreement use case.
 - Ability to ensure customer is properly informed of what participation entails, including any liability and risks.

Zach Woogen representing the Vehicle-Grid-Integration Council (VGIC) presented on process improvements that are necessary to enable mass-market adoption of the Flexible Service Agreement use case. While PCS has been the primary focus of discussion, acknowledgement was made to integrated or co-located energy storage as another option to enable the Flexible Service Agreement use case. In reference to the two participation options in SCE's LCMS pilot, VGIC believes the localized autonomous pathway is most feasible and suitable for EV charging use case in the near term as it has a better level of predictability compared to the communications-based pathway. Potential design elements for a Flexible Service Agreement framework were presented which includes:

- Customer Choice – It must be a customer choice to elect to participate in the Flexible Service Agreement use.
- Marketing, Education & Outreach – Customers need information on options to be informed and understand implications of electing to do Flexible Service Agreement. Roles and responsibilities between the customer, utility and third-party also need to be developed as part of the customer journey for participation.
- Customer Enablement Tools – Customer and developers need tools to interact with utilities, such as pro-forma applications and granular hosting capacity maps.
- Site & Technical Requirements – Technology vendors need clear rules and requirements which are consistent across utilities to scale product development and customer service offerings.
- Public Reporting – Stakeholders need clear and consistent data collected around the Flexible Service Agreement use case to inform the need for future program and/or rule revisions.

¹⁸ Including EV-related OIRs, Energization OIR, High DER OIR, Rule 21.

- Impact on Grid Planning – Load must be assessed dynamically and incorporated into utility planning.

Stakeholders discussed the maturity of the static limit use case and whether the pathways exist today to scale static limits. There was general stakeholder consensus that development of a framework would be a good first step to help guide the discussion and align stakeholders on the fundamental needs and objectives for the Flexible Service Agreement use case. ED Staff asked the panelist whether there are additional steps needed by the Commission or IOUs to enable UL 3141 apart from awaiting finalization. A framework was again referenced as something that would be useful to set guidelines on what implementation of UL 3141 practically looks like and requires based on technology type and use case.

Stakeholders raised the Integration Capacity Analysis (ICA) map and whether the ICA map could be a tool to gain better insight into where on the distribution system VGI could provide value. The current state of the ICA maps lack the granularity for customers or developers to see circuit level constraints but noted there are on-going discussions on improvements to the ICA maps within the High DER proceeding.

Part 3 - Future Procedural Priorities for VGI

The objective of Part 3 was to identify additional priority VGI topics that could be addressed in current proceedings related to TE Policy, TE Infrastructure or EV Interconnection. This session also allowed stakeholders to make recommendations for topics to be covered at the next VGI Forum. Part 3 was comprised of two panels; 1) IOU perspective and 2) Industry perspective on the emerging issues in interconnection and energization.

IOU Panel

Sarah Swickard representing PG&E, Danielle Weizman representing SDG&E, and Blake Evan Heidenreich representing SCE presented on the IOU perspective on other priority VGI topics. The group level set the discussion with a snapshot of various VGI workstreams today across the multiple relevant Commission proceedings.

Key recommendations from the IOUs include:

- Targeted scoping of VGI issues that address technical gaps and known barriers to VGI adoption within the new Transportation Electrification Policy and Investment¹⁹ proceeding.
 - A key issue emphasized by the IOUs was the need to better understand compensation mechanisms for customers and third-party service providers to ensure the proper incentives exists to encourage participation.
- The need for stakeholder discussion on appropriate and streamlined regulatory pathways to put forth proposals for VGI pilots and programs.
 - This should include discussions on what value streams or metrics need to be assessed in order to ensure rate payer funds are spent judiciously given the increasing pressures with affordability. ED Staff opined on the criticality of being able to articulate a clear scope of what will be proposed as well as demonstrate the value and impact any offering would bring relative to its cost to ratepayers.

Stakeholders raised whether there are opportunities to leverage VGI to support the distribution system operations, noting that system-level signals—such as time-of-use-rates—may be non-coincident with peaks on distribution circuits, thus exacerbating any distribution constraints. The IOUs acknowledged the critical role VGI has in supporting distribution operations and cited the examples discussed earlier in the Forum of dynamic rates which include a distribution component and Flexible Service Agreement use case to mitigate customer energization lead times on constrained distribution circuits. There was general consensus that potentially conflicting system-level and distribution-level signals speak to a need for a fundamental discussion on what and how grid needs should be prioritized and addressed.

Stakeholders also raised the value of modeling as a tool to inform many of the open questions related to VGI, citing that modeling can be capable of providing directional guidance while being less resource intensive relative to implementing a new pilot. The IOUs agreed and expressed the foundational role that modeling plays in making informed decisions. However, modeling results still need to be validated by real world tests. Process gaps and customer behavioral tendencies are also more difficult to ascertain through modeling.

¹⁹ R. 23-12-008

Stakeholders noted the lack of discussion on equity throughout the VGI Forum and emphasized the need to factor in and prioritize equity as part of transportation electrification efforts, especially for those in multi-unit dwellings who lack access to home charging. The IOUs acknowledged that equity has not been explicitly mentioned, since equity considerations are prioritized and inherent throughout the IOUs transportation electrification efforts. The example of equity requirements within programs funded by the California Air Resources Board's Low Carbon Fuel Standards program was cited as well as other Commission authorized infrastructure rebate programs which will often have carve outs to further support disadvantaged customers. ED Staff opined that the focus the Commission has on affordability is itself viewed through an equity lens.

Industry Panel

Anna Bella Korbatov representing Fermata Energy provided an introduction to Fermata Energy's product and service offerings as well as multiple successful examples of V2G deployments Fermata Energy has done across the nation. Fermata Energy's nationwide presence and V2X interconnection experience across multiple jurisdictions has given them a unique experience from which to draw lessons learned. Chief among these lessons relates to having a well-defined interconnection process which clearly communicates the process flow and timelines. The process should also include a dispute resolution process between third-parties and the IOU. From a technical perspective, V2X-specific commissioning tests are preferable over trying to fit V2X into an existing commissioning test, for example solar.

Fermata Energy also provided recommendations for quick-wins that the CPUC or CEC could consider:

- Create interconnection exemptions for CEC's Distributed Electricity Backup Assets (DEBA) program, Grant Funding Opportunities, Demand Side Grid Support (DSGS) program and SDG&E Dynamic Rate pilot to enable interconnection of V2G DC EVSE not certified to IL 1741-SA or SB citing the precedence of exemptions within Emergency Load Reduction Pilot program and PG&E and SCE's Dynamic Rate Pilots.
- Clarify the purpose of the CEC's V2G equipment list and its intended use to advance V2G.
- Reduction in interconnection fees per application, citing that interconnection fees in California are two to eight times that of other jurisdictions in the country.

For longer term actions to advance V2G:

- Improved hosting capacity maps to assist during the planning phases of a project.
- IOU process improvement to support higher volumes of V2G interconnection applications
- Incorporation of flexible or limited generation profiles to speed up the V2G interconnection process.
- Available equipment funding opportunities and economic value proposition through rates or programs to scale bi-directional charging. Citing examples such as SGIP.
- Utilize the Transportation Electrification Policy and Investment OIR²⁰ to address these shorter and longer term barriers.

Serj Berelson representing Mainspring Energy provided an introduction to Mainspring's product and service offerings that can support EV fleets through the addition of their fuel-flexible linear generators

²⁰ R.23-12-008

to provide additional capacity. Example deployment use cases were presented include a grid-parallel use case which can function to minimize power draw from the grid either continuously or during peak hours. Also presented was a grid-forming or islanded use case which can provide the site with power during grid outages. The product is able to seamlessly transfer between the two use cases and due to the fuel-flexible nature, can potentially lead to lower or negative emissions for the generator's use. An example of a successful deployment with Prologis for EV fleet charging was shared most notably reducing the energization timeline for the project from more than two years to eight months.

Michelle Bogen representing Ford Motor Company provided an introduction to Ford's Intelligent Back Up offering which allows the Ford F-150 Lightning to provide home backup power during grid outages using the vehicle, Ford Charge Station Pro (EVSE) and the Home Integration System. Based on early installations and participation in PG&E's Residential V2X Pilot, installation challenges emerged as a lesson learned in implementing V2H. There is high variability in what installation can entail based on factors such as site conditions—for example the location of the main service panel to the EVSE—or customer preferences for equipment location. The need for trenching can also add significant cost and complexity to an installation. Lack of knowledge and education on what is entailed in installation, can lead to misinformed customer expectations for installation cost and timelines. Therefore, greater customer education is needed to mitigate poor customer experience. Because there is such high variability in installation costs, incentive programs that could help customers offset these costs is recommended. Regarding the interconnection process, there are also opportunities for improvement as there was ambiguity on whether certain types of bi-directional EV chargers required interconnection or not, despite the V2H use case being non-exporting in this situation. The amount of interconnection review required should be informed by the use case to minimize unnecessary reviews. Interconnection processes that are consistent statewide are recommended to help mitigate this ambiguity. Furthermore, interconnection processes should include clear and streamlined processes that allow customers to update as use cases evolve. For example, customers initially using load-only or islanded modes should have a process to seek grid-parallel interconnection at a later date.

Attachment A: Agenda for Forum

Vehicle-Grid Integration Forum

Event Details

Date	Friday, March 22, 2024
Time	9:00 a.m. to 4:30 p.m.
Location	Pacific Gas & Electric Headquarters 300 Lakeside Drive, 1 st Floor Conference Room Oakland CA, 94612 OR Teams Meeting
Webinar and Teleconference Information	Microsoft Teams meeting Join on your computer, mobile app or room device Click here to join the meeting Meeting ID: 292 704 001 388 Passcode: prydGu Download Teams Join on the web Or call in (audio only) +1 415-906-0873,,26997928# United States, San Francisco Phone Conference ID: 269 979 28#

Agenda

Welcome and Introduction (9:00-9:20 a.m.)

- Introduction and safety message (Mike Delaney, Vice President, Utility Partnerships & Innovation, PG&E)
- CPUC introductory remarks (President Reynolds)

Part 1—Energy Division and CEC Staff Introduction (9:20-10:30 a.m.)

- **Objective:** Provide background information on relevant VGI work areas at the CPUC and CEC to provide a foundation for further discussion at the Forum and in this proceeding.
- CPUC Energy Division staff introduction to VGI Forum and VGI strategic focus areas
- CEC Staff presentation on VGI funding opportunities and technology enablement
- Panelists
 - o Audrey Neuman (CPUC)
 - o Achintya Madduri (CPUC)
 - o Jose Aliaga-Caro (CPUC)
 - o Raymond Breault (CPUC)
 - o Jeffrey Lu (CEC)

Break (10:30-10:45 a.m.)

Part 2—Identifying Near-Term Solutions to Support Flexible/Scaled Service Agreements and Deployment of Supporting VGI Technology, Including Automated Load Management (10:45-11:50 a.m.)

- **Objective:** Identify whether there are technical or regulatory barriers related to leveraging VGI technology to enable utilities to advance options for flexible/scaled service agreements, and identify potential quick-wins to address these barriers.
- **Panel 1:** IOUs present on status of and barriers to Automated Load Management and Power Control Systems to support flexible/scaled service agreements.
- Panelists
 - o Alex Portilla/ Neema Yazdi (PG&E)
 - o Roger Salas (SCE)
 - o Danielle Weizman (SDG&E)

Lunch (11:50 a.m. – 12:50 p.m.)

Part 2—cont. (12:50-1:45 p.m.)

- **Panel 2—**Industry perspective on opportunities and barriers to flexible/scaled service agreements and Automated Load Management and Power Control Systems deployment.
- Panelists:
 - o Marc Monbouquette (Enphase Energy)
 - o Jacqueline Piero (The Mobility House)
 - o Zack Woogen (Vehicle Grid Integration Council)

Break (1:45-2:00pm)

Part 3—Identifying Future Procedural Priorities and Topics for Future VGI Forums (2:00-3:45 p.m.)

- **Objective:** Identify additional needed action on VGI priorities, which could be addressed later in the TE Policy (R.23-12-008) and Infrastructure proceeding, or in other proceedings as appropriate, including discussion of interconnection and VGI. Allow industry to discuss perceived challenges and barriers to connection of EVSE and VGI technologies to the grid (including energization and interconnection).
- **Panel 1:** IOU representatives share VGI priorities

Each large IOU presents VGI priorities that the Commission and stakeholders could address within R.23-12-008 and/or the next VGI Forum (beyond what the Forum already addresses).

- Panelists
 - o Sarah Swickard (PG&E)
 - o Blake Even Heidenreich (SCE)
 - o Danielle Weizman (SDG&E)

- **Panel 2:** Industry perspective on the emerging issues in interconnection/energization
- Panelists
 - Anna Bella Korbatov (Fermata Energy)
 - Kent Leacock (Mainspring Energy)
 - Michelle Bogen (Ford)

Closing Remarks (3:40-3:45 p.m.)

Attachment B: Presenter Slides

Vehicle-Grid Integration Forum

Audrey Neuman

Senior Transportation Electrification Analyst

Energy Division | CPUC

March 22, 2024



California Public
Utilities Commission

March 22nd VGI Forum Agenda

- Welcome and Introduction (9:00-9:20 a.m.)
- **Part 1—CPUC Energy Division and CEC Staff Introduction** (9:20-10:20 am)
 - **Objective:** Provide background information on relevant VGI work areas at the CPUC and CEC to provide a foundation for further discussion at the Forum and in the relevant proceedings.
- **Part 2—Identifying Near-Term VGI Solutions to Support Flexible/Scaled Service Agreements and Deployment of Automated Load Management** (10:30-11:40am + 12:50-1:45 pm)
 - **Objective:** Identify whether there are quick-wins to address technical or regulatory barriers related to leveraging VGI technology to enable utilities to advance options for flexible/scaled service agreements.
- **Part 3—Identifying Future Procedural Priorities and Topics for Future VGI Forums** (2:00-3:45 pm)
 - **Objective:** Identify additional needed action on VGI priorities, including grid connection barriers, which could be dealt with later in the TE proceeding, or in other proceedings as appropriate.

Part 1: CPUC Energy Division and CEC Staff Introduction

VGI Definition

D.20-12-029 defines vehicle-grid integration as:

- Any method of altering the time, charging level, or location at which grid-connected light-duty electric vehicles, medium-duty electric vehicles, heavy-duty electric vehicles, off-road electric vehicles, or off-road electric equipment charge or discharge in a manner that optimizes plug-in electric vehicle or equipment interaction with the electric grid and provides net benefits to ratepayers by doing any of the following:
 - A) Increasing electrical grid asset utilization and operational flexibility.
 - B) Avoiding otherwise necessary distribution infrastructure upgrades and supporting resiliency.
 - C) Integrating renewable energy resources.
 - D) Reducing the cost of electricity supply.
 - E) Offering reliability services consistent with the resource adequacy requirements established by Section 380 or the Independent System Operator tariff.

VGI Forum Objectives from D.22-11-040

- Provide a venue to comprehensively discuss VGI topics that cut across multiple proceedings.
- Explore the adopted VGI strategic focus areas.
- Create an opportunity for further guidance on VGI policy, and for strategic communication, information sharing, and discussion of relevant VGI issues with stakeholders.
- To the extent feasible and relevant, incorporate learning from the VGI Forums into both Funding Cycle 0, Funding Cycle 1, and/or other Commission venues.
- Offer a venue for stakeholders to raise emerging or persistent issues related to VGI.

Objectives for March 22nd VGI Forum

- Serve as a starting point to address VGI barriers within R.23-12-008, with a focus on identifying quick-wins.
 - Identify VGI solutions to support flexible/scaled service agreements, including identifying quick-wins for enabling automated load management (ALM);
 - Identify other VGI priorities and barriers for the IOUs and OIR to address within the next year, as relevant.
- Tee up potential priorities for the next VGI Forum (end of 2024), and for the CPUC to address in R.23-12-008 or other CPUC procedural venues.
- While there are other critical objectives for VGI (e.g., compensation), they will require ongoing policy development and research, and will not be the main focus of today's forum.

D.22-11-040 Established 3 VGI Strategic Focus Areas

Rates and Demand Flexibility

- Objectives:
 - Ensure rates for charging and discharging are revenue neutral.
 - Develop rates and price signals to ensure EVs can benefit the grid, and encourage third-party innovation.
 - Ensure vehicles are a flexible load that can provide grid benefits and services.

Technology Enablement

- Objectives:
 - To further VGI, enable technology adoption and reduce/eliminate barriers to deployment.
 - Role of the IOUs and CPUC is to reduce and eliminate barriers, and provide opportunities for the market to deploy novel VGI-focused technology.

VGI & Planning

- Objectives:
 - Develop common VGI inputs and assumptions for use across planning processes to ensure we do not over or under build grid infrastructure.

Key Policy Questions for Consideration at Today's VGI Forum

What are current barriers to expansion of scaled/flexible service agreements and the technology that enables them?

What are the risks, unknowns, and limits of enabling flexible/scaled service agreements at scale?

What are the risks and unknowns associated with increased deployment of Automated Load Management and Power Control Systems?

What are the technical definitions for V2H, V2G, and V2B, and which grid connection pathways should be applicable to each?

What other VGI solutions can support flexible/scaled service agreements in the near-term, and what are the barriers to their deployment?

What are quicker actions the IOUs and CPUC can take to enable pathways for flexible/scaled service agreements and supportive VGI technologies?

What are achievable VGI priorities for the next year?

What longer lead-time priorities should be the focus of future forums and the TE or other CPUC proceedings?



California Public Utilities Commission

Audrey Neuman

Senior Analyst, Transportation Electrification

audrey.neuman@cpuc.ca.gov



California Public
Utilities Commission

Status of VGI in the California Demand Flexibility OIR (R.22-07-005)

Achintya Madduri, PhD

Senior Analyst | Retail Rates | Energy Division | California Public Utilities Commission



Demand Flexibility OIR (R.22-07-005)

Summary and Goals

- 1. Develop policies to achieve widespread customer adoption of automated demand flexibility solutions throughout the state**
 - Reduce long-term system costs through more efficient pricing of electricity to:
 - Make electricity bills more affordable and equitable, and,
 - Enable widespread building/transportation electrification.
 - Develop scalable solutions that accommodate participation by both bundled and unbundled customers
- 2. Ensure IOUs comply with CEC's adopted Load Management Standards (LMS) Amendments for dynamic hourly, cost-based rates**

Relationship to VGI

- 1. Will the VGI ecosystem adopt rates that incorporate hourly dynamic prices?**
- 2. Will the VGI ecosystem ****respond**** to rates that incorporate hourly dynamic prices?**

Key Challenges for California: Affordability and Reliability

- **Residential Rate Challenge: Up to 40% of Californians are experiencing a range of affordability issues.**
 - Forecasts show rates rapidly outstripping inflation over the next decade.
- **Current rate offerings are not incentivizing behavior that can reduce long-term electric system costs**
- **Silver Linings?**
 - EV sales momentum + greater electrification can lead to lower household energy costs.
 - A statewide **Flexible Unified Signal for Energy (CaIFUSE)** aims to reform rates to create more value for all customers.



Vision for Demand Flexibility



...leading to a reduction in peak loads, energy prices, and required infrastructure...



Lower peak load means less infrastructure cost..

...and customers buy more electricity when it is cheaper



- Widespread adoption of demand flexibility solutions
- Reduced peak loads, energy prices, infrastructure needs
- Reduced cost of service

California Flexible Unified Signal for Energy – CalFUSE “Framework”

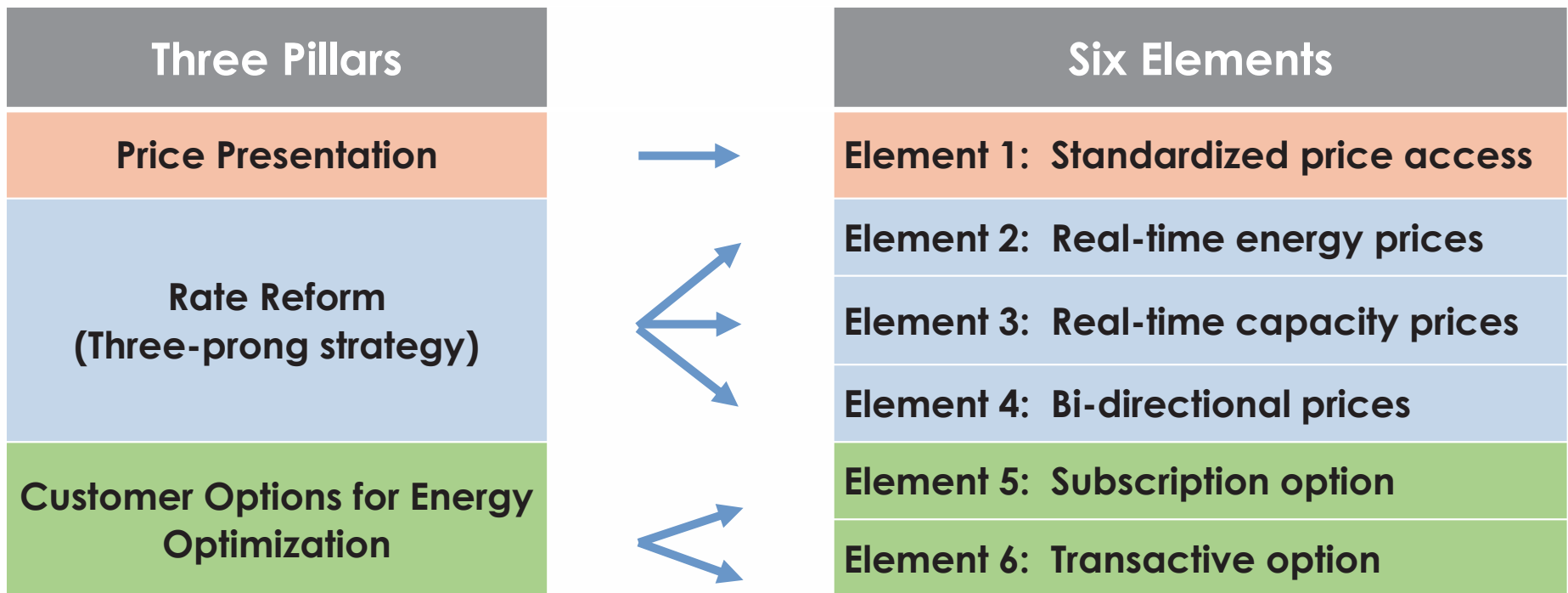

SCE CalFUSE Pilot – Illustrative Winter/Summer Prices

Composite Hourly Prices based on Hourly Capacity Utilization & CAISO LMP

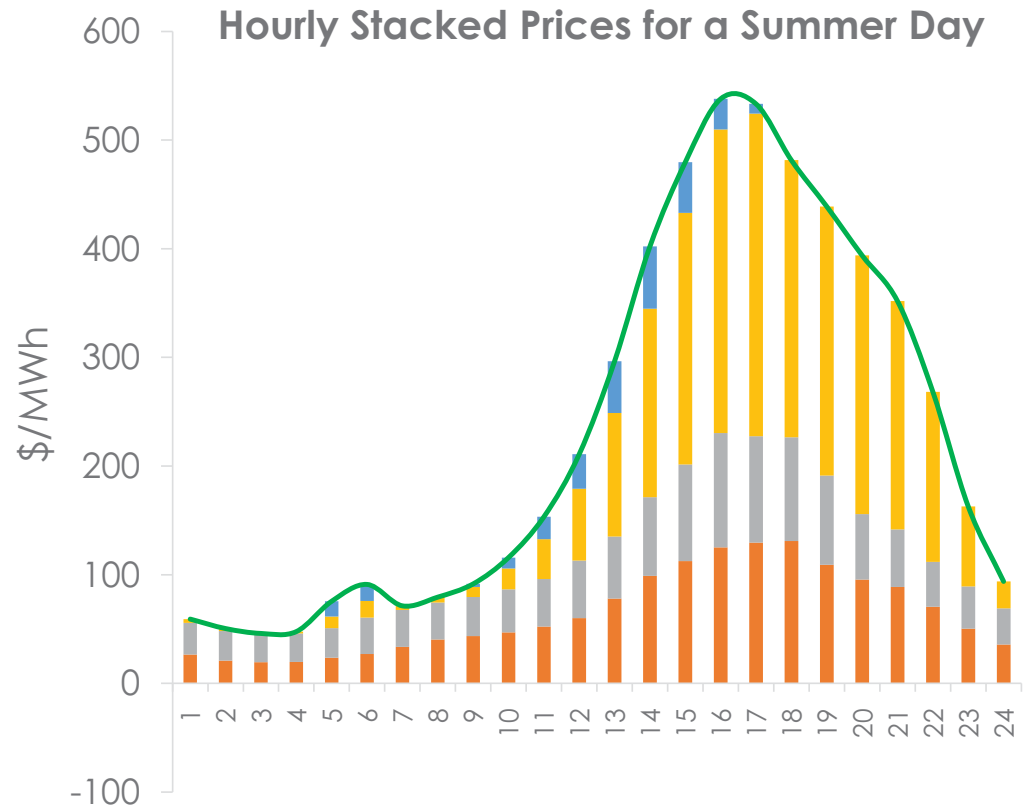
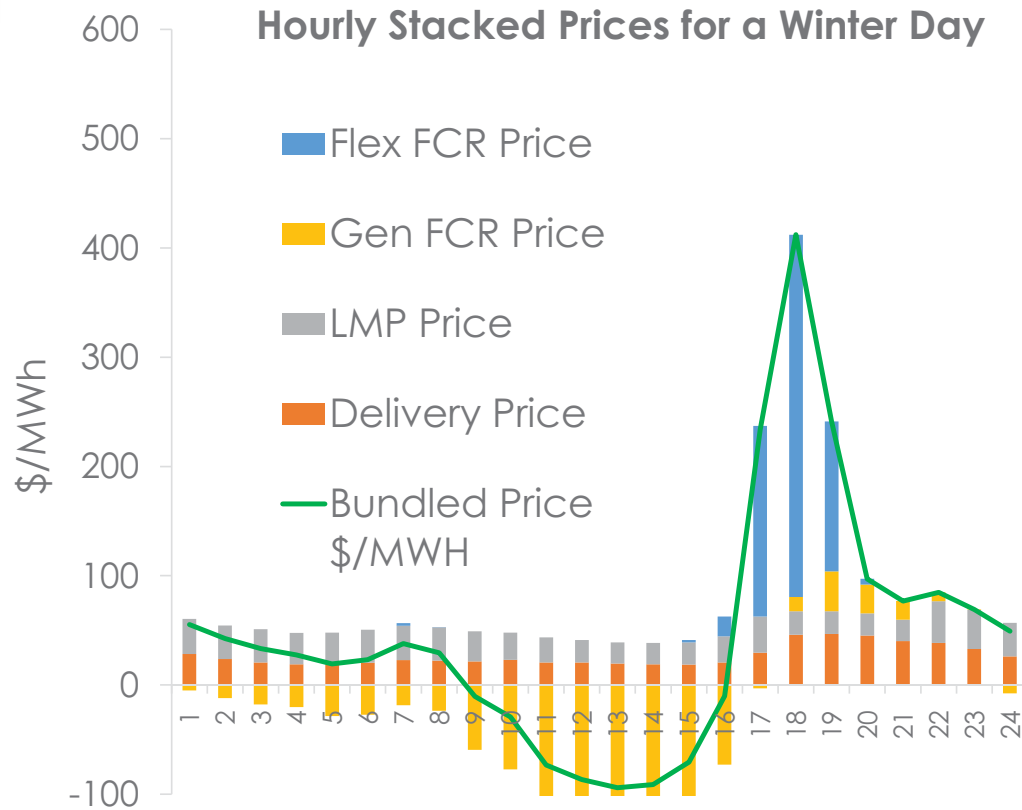

Timelines for Dynamic Retail Rates in CA

Date	Milestone
Mid 2024	Expanded CalFUSE Pilots to launch in SCE and PG&E(D.24-01-032) <ul style="list-style-type: none"> • Pilots include eligibility for VGI (including submetering) • Enrollment target of 150 MW by 2027
Late 2024	PG&E V2X Pilot (SB 676) Phase 2 to launch <ul style="list-style-type: none"> • 1-year pilot that will provide export compensation for bidirectional EV charging on a CalFUSE rate for residential and commercial fleets
2024-2026	IOUs to submit applications for opt-in dynamic hourly rates in response to CEC Load Management Standards
2027	CEC Load Management Standards require that large IOUs and CCA offer dynamic hourly rates for all customer classes
2030	CEC's adopted CA load shift goal – 7,000 MW



For More Information:

- [Staff Proposal on CalFUSE Framework](#)
- [Demand Flexibility Rulemaking](#)

Contact: achintya.madduri@cpuc.ca.gov



California Public
Utilities Commission

Interconnection and Distribution Engineering: Vehicle-Grid Integration Forum

Eric Martinot (Presenter)

Senior Regulatory Analyst

Energy Division | CPUC

Jose Aliaga-Caro (EVSE Interconnection Lead)

Utilities Engineer

Energy Division | CPUC

March 22, 2024

Contact: Jose.Aliaga-Caro@cpuc.ca.gov



California Public
Utilities Commission

EVSE Interconnection: Relevant Documents

Rule 21 is a tariff that describes the interconnection, operating and metering requirements for certain generating and storage facilities seeking to connect to the electric distribution system.

- [Working Group Three Final Report](#) (June 14, 2019)
 - Discussed Issue 23: Should the Commission consider issues related to the interconnection of electric vehicles and related charging infrastructure and devices and, if so, how?
- [Final Report of the Vehicle to Grid Alternating Current Interconnection Subgroup](#) (Dec. 11, 2019)
- [Decision 20-09-035: Decision Adopting Recommendations from Working Groups Two, Three, and Subgroup](#) (Sept. 30, 2020)
 - [Decision D2101027 - Order Correcting Errors in Decision 20-09-035](#)
 - Adopted Issue 23 proposals that had consensus; and guidance for V2G AC systems
- **SDG&E Advice Letter (AL) 3774-E, SCE AL 4510-E, and PG&E 6209-E** (May 28, 2021)
 - Presents (1) the implementation plan for Proposal 23e, which allows V2G DC EVSE that has connected as load-only to switch to bidirectional mode upon receiving PTO from the utility, and (2) proposed temporary pathway for V2G AC EVSE interconnection (V2G AC Pilot)
- [Resolution E-5165: Approval, with Modifications, of Vehicle-to-Grid Implementation Plans and Technical Requirements in Compliance with Decision 20-09-035](#) (November 5, 2021)
- **PG&E AL 6500-E, SDG&E AL 3955-E, and SCE AL 4718-E** (February 11, 2022)
 - Submitted to incorporate Resolution E-5165's modifications
- **PG&E AL 7125-E, SCE AL 5185-E, and SDG&E AL 4350-E** (January 5, 2024)
 - Recommends (1) extending the V2G AC Pilot with the same requirements for an additional two years, and (2) further study of V2G AC interconnection pathways
- **Resolution Disposing of PG&E AL 7125-E, SCE AL 5185-E, and SDG&E AL 4350-E -- FORTHCOMING**

EVSE Interconnection Landscape

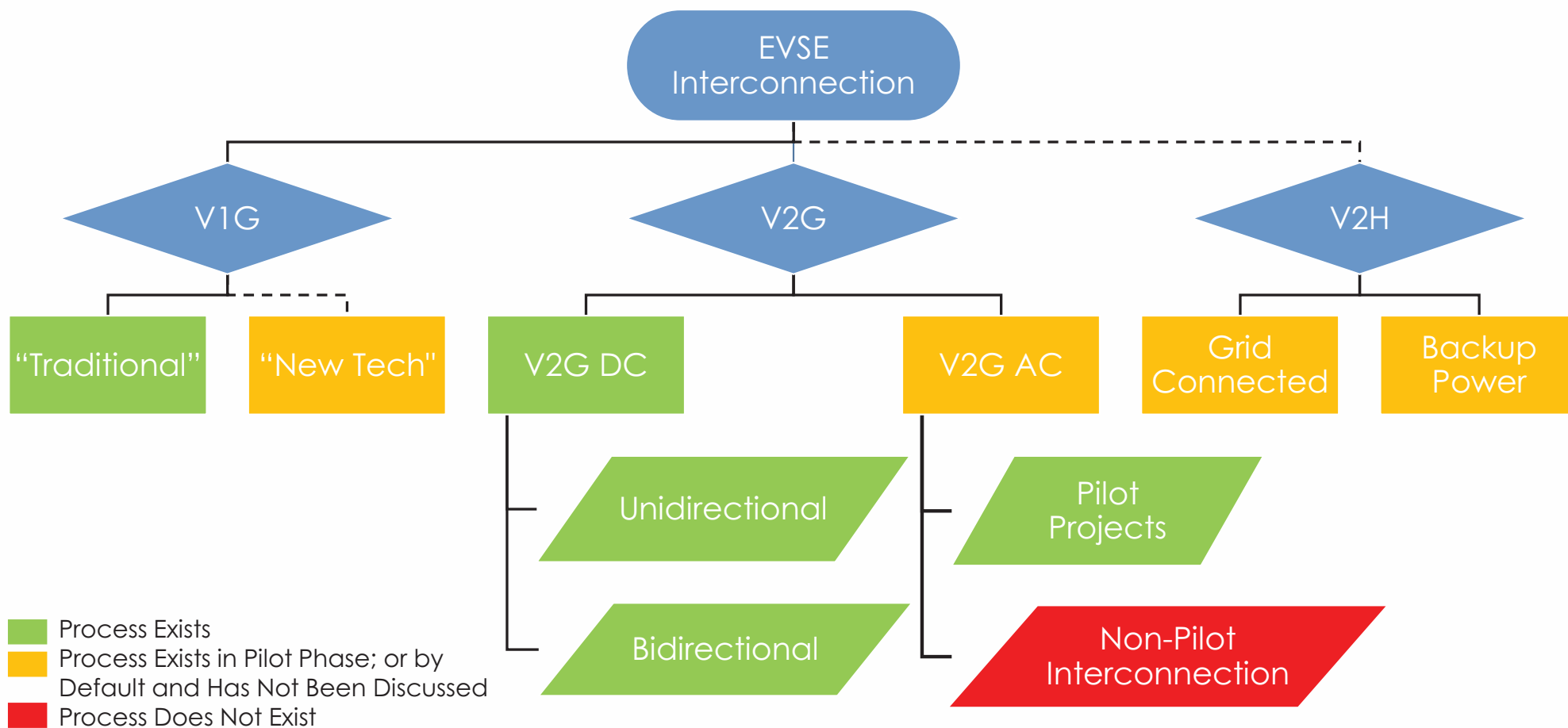

EVSE Interconnection: V1G

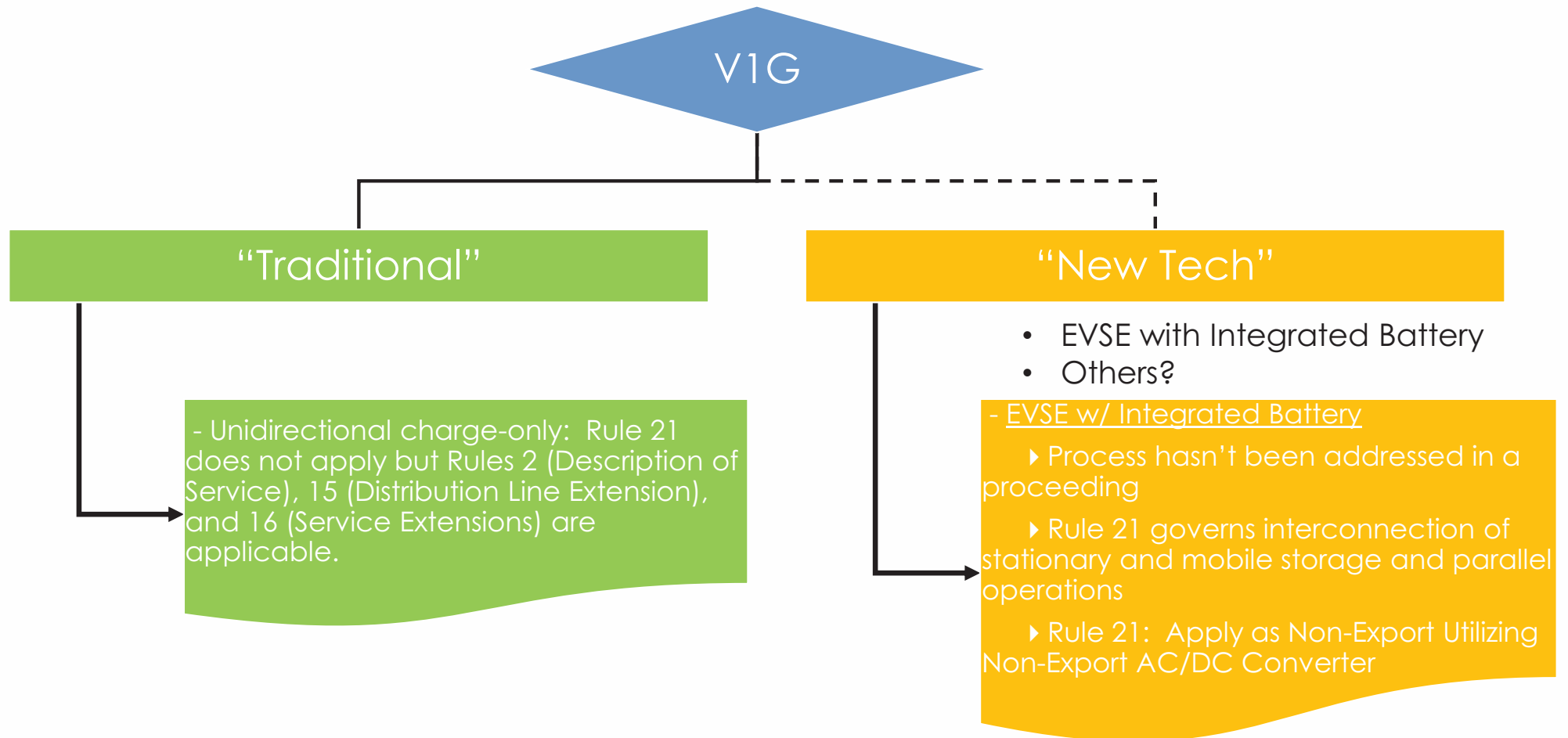

EVSE Interconnection: V2G

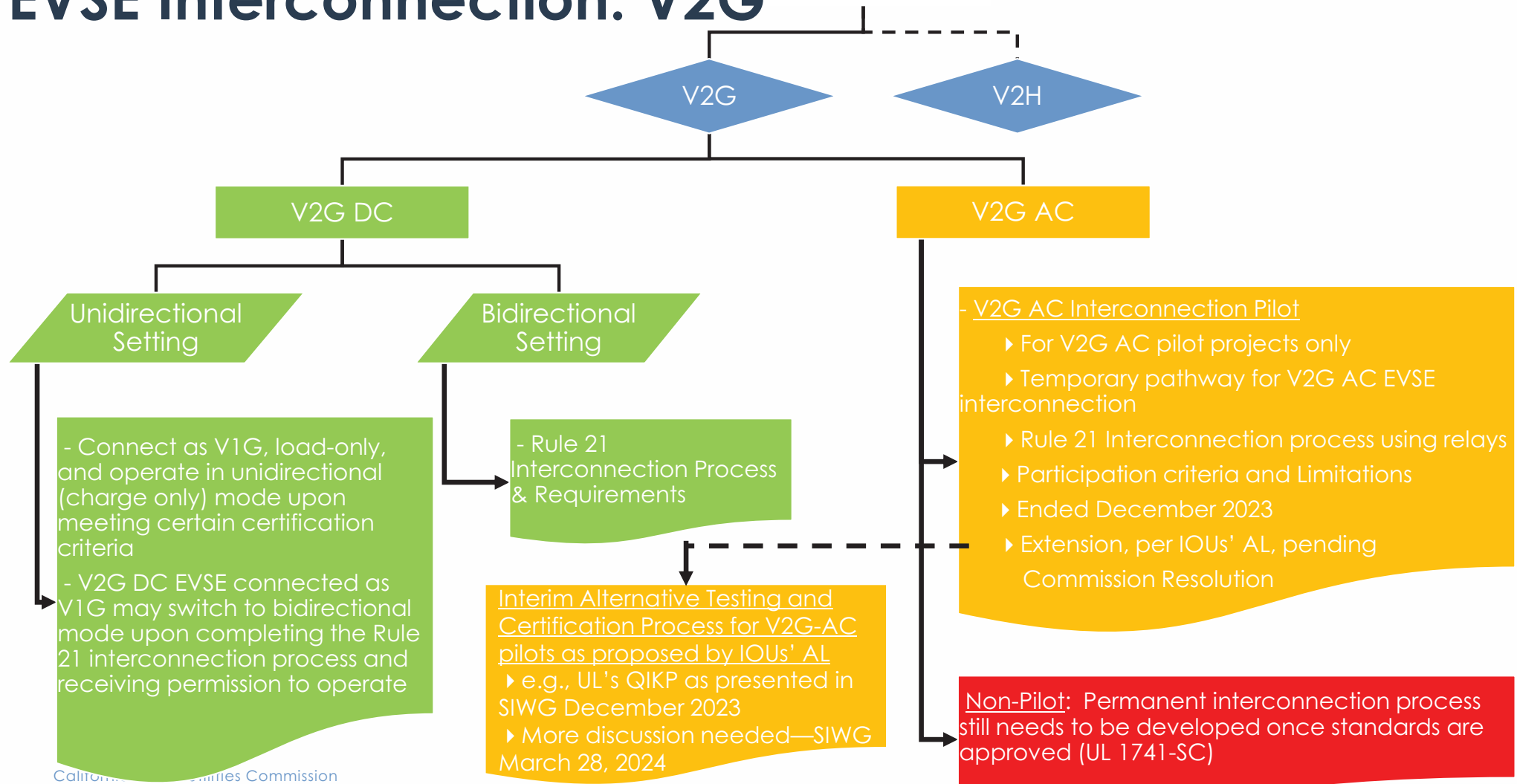

EVSE Interconnection: V2H

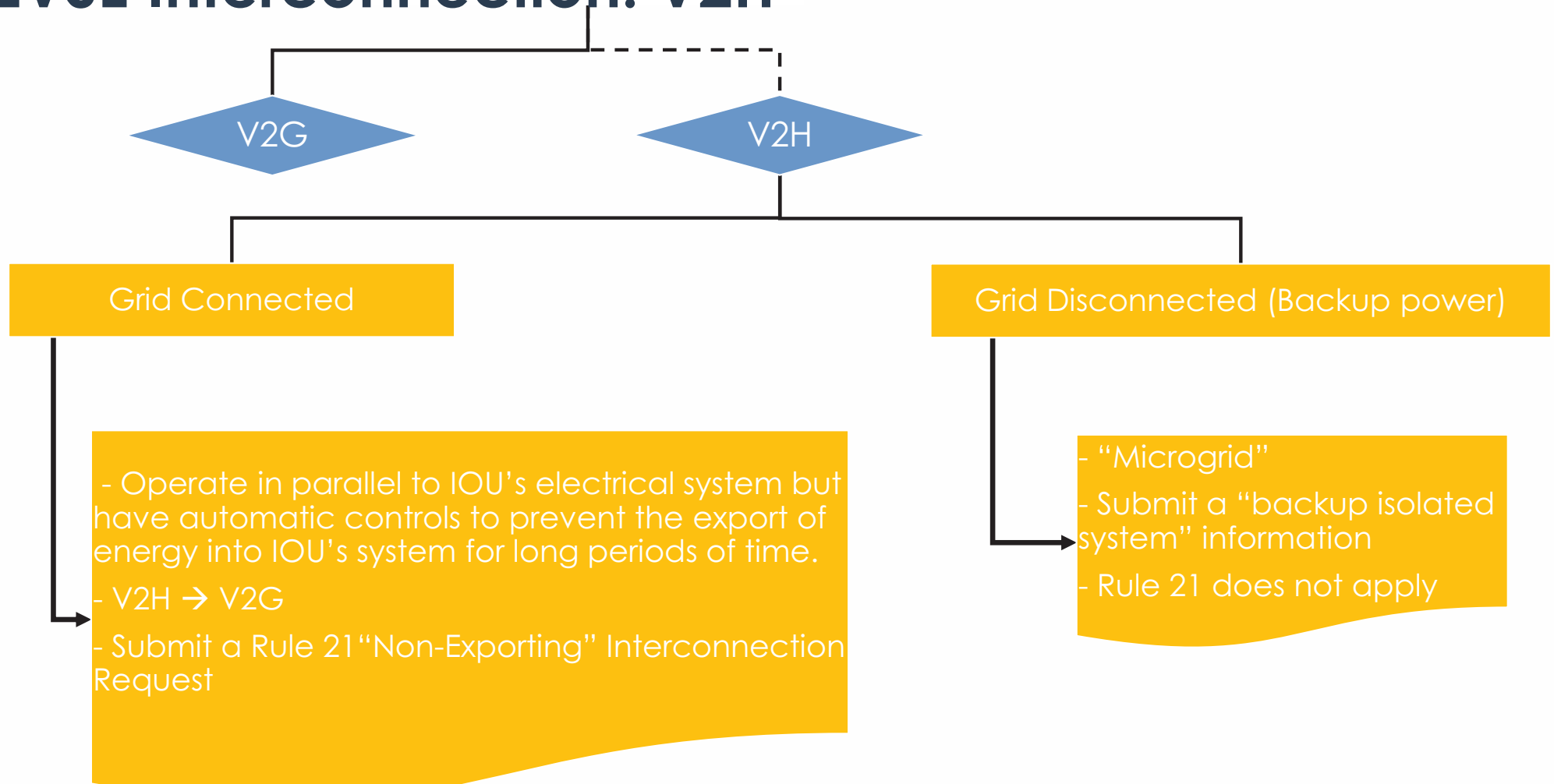



California Public Utilities Commission

For additional information on EVSE Interconnection
contact:

Jose.Aliaga-Caro@cpuc.ca.gov

High DER Future – Smart Inverter Operationalization Working Group: Vehicle-Grid Integration Forum

Raymond Breault

Utilities Engineer

Energy Division | CPUC

March 22, 2024

Contact: raymond.breault@cpuc.ca.gov



California Public
Utilities Commission

Rulemaking 21-06-017: SIOWG - History, Background, & Scope

Smart Inverter Working Group (SIWG)

- Started in 2013 in Interconnection Rulemaking
- Developed functional requirements for inclusion in Rule 21 Interconnection Tariff
 - Phase 1: autonomous (default) functions
 - Phase 2: Establish communication protocols
 - Phase 3: Advanced Inverter Functions
- Various Decisions, Advice Letters, and Resolutions determined which smart inverter functions became operational and mandatory.

Smart Inverter Operationalization Working Group (SIOWG)

- Formed under Track 3 Phase 1 within the “*Order Instituting Rulemaking to Modernize the Electric Grid for a High Distributed Energy Resources Future*”, Rulemaking 21-06-017
 - Tasked with identifying priority use cases that leverage the capabilities of smart inverters and provide value to grid operators and ratepayers and recommending how to operationalize these use cases.
 - Previously established smart inverter functionality focused on interconnection and operation of export generation from PV and storage, but not the import of electricity staying within the confines of Rule 21.
 - The SIOWG looked holistically at business cases within Rule 21 and beyond to include Import Limits, Electric Vehicles, Community Microgrids, and CAISO Services.
 - To better address the scoping questions of the SIOWG, a new broader definition of Smart Inverters was used within the report: “A type of DER unit using controllable DC to AC converters.”
 - The overarching focus of the SIOWG was operational flexibility – that is, the ability of a power system to respond reliably and safely to changes in electricity demand and generation
-
- The Smart Inverter Operationalization Cyber Security working group (SIO-CS), was formed concurrently to produce their own report to determine what existing cybersecurity standards should be applied to Smart Inverters & DERMS to ensure communications between the equipment and management systems are secure for DERS

Key Findings of T3P1 SLOWG Report

The SLOWG has identified **operational flexibility** as the topmost priority:

- To DSOs' ability to use operational flexibility to **optimize capacity utilization** in a high DER future.
- Operational flexibility may **enable faster connections of DER** (generations and loads) **without grid infrastructure upgrades** while **ensuring grid safety and reliability**

The following concepts have been introduced to support operational flexibility.

- **Firm export/import limits of power:** Guaranteed upper limit under normal conditions (such as *90% of the lowest value in the Integration Capacity Analysis - Static Grid (ICA-SG)*) as more DER (**interconnection** or **energization**) are connected to the grid.
- **Non-Firm export /import Capacity:** Non-guaranteed capacity that the DER facility can **export** or **import** beyond the Firm limit, such as the highest value in ICA-SG minus Firm limit, as more EVs and other loads need temporarily limited energization while waiting for distribution upgrades. DSOs can authorize Non-Firm **export** or **import** capacity when this would not impact grid safety or reliability.
- **Minimum export /import Requirement:** The contractually required minimum **export** or **import** in active power (watts) at the Point of Common Coupling (PCC) (i.e., site of DSO revenue meters) during the specified time period.
- **Command export /import:** The Distribution System Operate may issue commands during abnormal grid scenarios to reduce or supplement exports and imports as necessary to promote grid stability

Business Case E: Operational Flexibility For Electric Vehicles Providing Distribution Services

Business Case E addresses the capabilities and potential requirements for Electric Vehicles to provide distribution grid support services while charging and/or discharging (i.e. bidirectional charging), similar to those provided by grid-connected DER.

- The purposes of EV distribution Grid Services fall into the following Categories: 1) Minimize impact on the grid 2) Provide Benefits to the grid 3) Provide benefits to EV Owners 4) Provide societal benefits
- Six Use Cases were identified as high priority for potentially being able to support the requirements for Business Case E
 - Use Case #E1: EV Peak Power Limiting - Enables demand response and import limiting in cases where planned or emergency load reduction is needed
 - Use Case #E4: Volt-Watt Response by EVs – Utilizes Volt-Watt to reduce power and maintain appropriate voltages to charging EVs when needed
 - Use Case #E8: Coordinated Charge/ Discharge of EVs – Ensure Desired State of Charge is Reached at the Requested Time while considering factors such as forecasted energy prices, load import limits, EV ability to provide other services
 - Use Case #E9: V2G EV as DER (Meeting Rule 21 Tariff requirements) - allows for Vehicle to Grid power flow to aid in load balancing
 - Use Case #E12: Watt-Var function – Allows for more controlled and balanced V2G discharging
 - Use Case #E15: Limit Active Power Export function – Promotes appropriate power discharge into the grid

Note: High Level goals were named Business cases ("What"), while technical operations supporting the Business Cases were named Use Cases ("How").

Challenges of T3P1 SLOWG Report

- **Export** and **import** limits must be managed by a **Power Control System (PCS)** and tested at the **Point of Common Coupling (PCC)** (i.e., site of DSO revenue meters) rather than at individual DER connection points.
- **Schedules** and/or **commands** of **export** and **import** limits will need to be **dynamic** and become **more granular**, namely by week, day of week, day, hour of day.
- The CPUC will need to determine the **regulations and tariffs necessary** to **support** this **operational flexibility** fairly and effectively. **Regulations** and **tariffs** need to consider whether **export** and **import** limits should be handled in **one proceeding** or in **two well-coordinated proceedings**. Many DERs have both **generation** and **load** attributes.
- **Timelines** for Technology and Testing:
 - The **DSOs** will need to ensure that their **power management systems** (ADMS, DERMS, and others) can **assess** the actual **capacity available** on **different circuits**, **send schedules and commands**, **verify performance**, and **take** any necessary **corrective actions**. The timeframe is an **estimated 2-5 years** of DSO development.
 - The **DSOs** and the **DER facilities** (and their aggregators) will need to support the **communications**. The deployment over an **estimated 2 to 10 years** with pilot projects and a focus on the larger DER facilities.
 - **Testing and certification requirements** will need to be developed and/or updated **to reflect** the new scheduling and command requirements **supported by Power Control Systems** rather than only type-testing of individual DER units. The **estimated timeframe is 1-2 years**.

Next Steps & Tentative Schedule

- Q1 - Finalize and publish the Business & Use Case report
 - SIOWG Report distributed to Service List February 1
 - Comments & Reply Comments Pending
- Q 1&2 - Cybersecurity Subgroup report
 - Draft received by ED Staff
 - Issue both Reports as Ruling with questions
 - Comments & Reply Comments
- Q 2 & 3 - Staff Proposal - A future Staff Proposal will recommend CPUC actions based on the working group reports, party comments, staff research and analysis, and consultant perspective.
 - Working on detailed schedule
 - Comments & Reply Comments
- Q 4 - Proposed Decision TBD



2024 CPUC/IOU Vehicle-Grid Integration Forum

CEC Efforts Enabling Vehicle-Grid Integration

March 2024 | Jeffrey Lu, Staff

Four general categories of CEC VGI efforts



Tech Funding

- EV charger funding via block grants and solicitations
- Charging related and load flex funding



Regs / Programs

- Load Management Standards (marginal cost rates)
- Demand Side Grid Support (DSGS) Program



Analysis / Reports

- Integrated Energy Policy Report
- AB 2127 Statewide Charging Infrastructure Assessment



Standards Support

- Minimum standards for CEC funding
- Needs analysis
- V2G Equipment List

CEC is committed to realizing widespread VGI and load flexibility

- **Over \$500M* available** in recent and near-term CEC funding opportunities to support VGI and load flex technology enablement
- Funding may be disbursed via various CEC divisions
 - Fuels and Transportation
 - Energy Research and Development
 - Reliability, Renewable Energy & Decarbonization Incentives

California Public Utilities Commission
*Availability of certain funds is subject to project performance and/or pending state budget provisions

Recent opportunities (now closed)

<p><u>GFO-22-609</u> REDWDS</p>	<p><u>GFO-22-612</u> School Bus Bidi Infra</p>	<p><u>GFO-22-615</u> Innovative MDHD Charging</p>
<ul style="list-style-type: none"> • ~\$20M in proposed Phase 1 awards, up to another ~\$188M in Phase 2 awards • Demonstrate products that manage charging in response to dynamic signals • Phase 2 funds subject to project performance and funding availability 	<ul style="list-style-type: none"> • ~\$10.8M in proposed awards • Deployment of bidi charging at school bus yards with enrollment in export compensation program (such as ELRP, DSGS) • Possible Phase 2 funding 	<ul style="list-style-type: none"> • ~\$33M in proposed awards • Demonstrate innovative business model or charging solution for MDHD EV applications • Minimum deployment of 10 chargers as part of demonstration

Pending and upcoming opportunities (1/2)

<p><u>GFO-23-306</u> Grid Supportive Electrification</p>	<p><u>GFO-23-309</u> VPP-FLEX</p>
<ul style="list-style-type: none">• \$21M available across 3 project groups• Demonstrate products that enable flexible load management for upgrade deferral, DC hub architecture, or grid friendly opportunity charging solutions• March 29 application deadline <i>(soon!)</i>	<ul style="list-style-type: none">• \$21M available across 2 project groups• Demonstrate VPP with automated load shifting in partnership with a local government or nonprofit, or interoperable energy management systems for commercial buildings• July 1 application deadline

Pending and upcoming opportunities (2/2)

<p style="text-align: center;"><u>[GFO # TBD]</u> Draft DEBA DER</p>	<p style="text-align: center;"><u>[GFO # TBD]</u> Tech Enablers for EVs As DERs</p>
<ul style="list-style-type: none"> • \$250M available across 3 project groups • Demonstrate deployment of large DERs, VPPs, or load flex aggregation with minimum 6-15 MW capacity • Earliest deployments must be complete in time for summer 2025 and reimbursement will be contingent on DER performance • Anticipated release in next 1-2 months 	<ul style="list-style-type: none"> • \$12.6M expected to be available • Would fund research, development, and demonstration of telematics-based metering and AC V2G • Anticipated release June-September 2024

PG&E Flexible Service Connection

VGI Forum – Program Overview

Panel 1: IOUs present on status of and barriers to Automated Load Management and Power Control Systems to support flexible/scaled service agreements.

March 2024 – Grid Innovation



Together, Building
a Better California



Context Setting: The need for new DER Management Tools & Processes

PG&E anticipates increased load driven by EV adoption and building electrification – coupled with continued adoption of distributed solar, significant growth of behind-the-meter storage and flexible loads.

New tools and processes to orchestrate Distributed Energy Resources (DERs) are necessary to safely and effectively operate the grid.

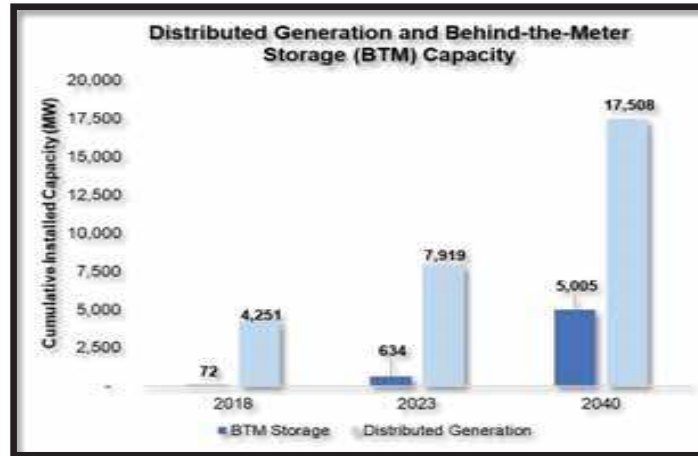
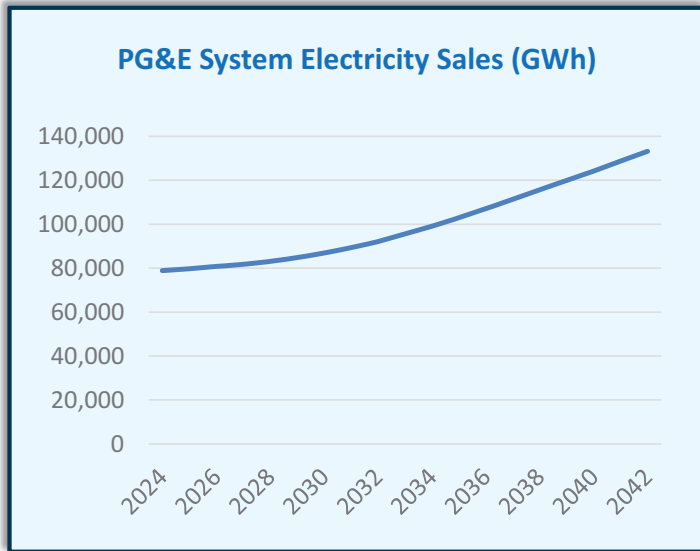

7/25 PG&E Innovation Summit announcing DERMS Initiative

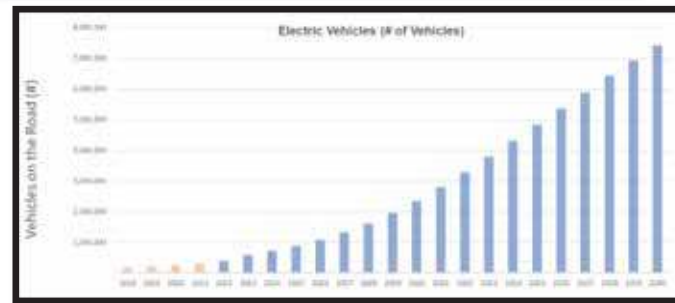

Source: PG&E's Spring 2023 Annual Load Forecast



PG&E's Flexible Service Connection Concept

Flexible Service Connection aims to allow customers with controllable loads to connect to the system without waiting for a service upgrade as a bridge solution



Customer Value

Quicker connections

- Avoid Long Wait Times
- More Available Energy
- Improved Utility Partnership



Distribution Value

Improved customer experience

- Unlock Available Capacity
- Higher Grid Utilization
- Operational Flexibility



Energy System Value

Support EV industry goals

- Timely Energization
- Cost Effectiveness
- Manage Grid Constraints



Real World Example of Potential Benefits

Month -->	Jan	Feb	Mar	Apr	May	Jun	Jul	Aug	Sep	Oct	Nov	Dec
0	71%	71%	71%	20%	20%	20%	20%	20%	20%	20%	71%	71%
1	71%	71%	71%	20%	20%	20%	20%	20%	20%	20%	71%	71%
2	71%	71%	71%	20%	20%	20%	20%	20%	20%	20%	71%	71%
3	71%	71%	71%	20%	20%	20%	20%	20%	20%	20%	71%	71%
4	71%	71%	71%	20%	20%	20%	20%	20%	20%	20%	71%	71%
5	71%	71%	71%	20%	20%	20%	20%	20%	20%	20%	71%	71%
6	71%	71%	71%	20%	20%	20%	20%	20%	20%	20%	71%	71%
7	71%	71%	71%	20%	20%	20%	20%	20%	20%	20%	71%	71%
8	71%	71%	71%	20%	20%	20%	20%	20%	20%	20%	71%	71%
9	71%	71%	71%	20%	20%	20%	20%	20%	20%	20%	71%	71%
10	71%	71%	71%	20%	20%	20%	20%	20%	20%	20%	71%	71%
11	71%	71%	71%	20%	20%	20%	20%	20%	20%	20%	71%	71%
12	71%	71%	71%	20%	20%	20%	20%	20%	20%	20%	71%	71%
13	71%	71%	71%	20%	20%	20%	20%	20%	20%	20%	71%	71%
14	71%	71%	71%	20%	20%	20%	20%	20%	20%	20%	71%	71%
15	71%	71%	71%	20%	20%	20%	20%	20%	20%	20%	71%	71%
16	71%	71%	71%	20%	20%	20%	20%	20%	20%	20%	71%	71%
17	71%	71%	71%	20%	20%	20%	20%	20%	20%	20%	71%	71%
18	71%	71%	71%	20%	20%	20%	20%	20%	20%	20%	71%	71%
19	71%	71%	71%	20%	20%	20%	20%	20%	20%	20%	71%	71%
20	71%	71%	71%	20%	20%	20%	20%	20%	20%	20%	71%	71%
21	71%	71%	71%	20%	20%	20%	20%	20%	20%	20%	71%	71%
22	71%	71%	71%	20%	20%	20%	20%	20%	20%	20%	71%	71%
23	71%	71%	71%	20%	20%	20%	20%	20%	20%	20%	71%	71%



Month -->	Jan	Feb	Mar	Apr	May	Jun	Jul	Aug	Sep	Oct	Nov	Dec
0	100%	100%	100%	100%	100%	100%	92%	100%	99%	100%	100%	100%
1	100%	100%	100%	100%	100%	100%	98%	100%	100%	100%	100%	100%
2	100%	100%	100%	100%	100%	100%	100%	100%	100%	100%	100%	100%
3	100%	100%	100%	100%	100%	100%	100%	100%	100%	100%	100%	100%
4	100%	100%	100%	100%	100%	100%	100%	100%	100%	100%	100%	100%
5	100%	100%	100%	100%	100%	100%	100%	100%	100%	100%	100%	100%
6	100%	100%	100%	100%	100%	100%	100%	100%	100%	100%	100%	100%
7	100%	100%	100%	100%	100%	100%	100%	100%	100%	100%	100%	100%
8	100%	100%	100%	100%	100%	100%	100%	100%	100%	100%	100%	100%
9	100%	100%	100%	100%	100%	100%	100%	100%	100%	100%	100%	100%
10	100%	100%	100%	100%	100%	100%	100%	100%	100%	100%	100%	100%
11	100%	100%	100%	100%	100%	100%	100%	100%	100%	100%	100%	100%
12	100%	100%	100%	100%	100%	100%	100%	100%	100%	100%	100%	100%
13	100%	100%	100%	100%	100%	100%	100%	100%	100%	100%	100%	100%
14	100%	100%	100%	100%	100%	100%	100%	100%	100%	100%	100%	100%
15	100%	100%	100%	100%	100%	100%	100%	100%	100%	100%	100%	100%
16	100%	100%	100%	100%	100%	100%	89%	94%	83%	100%	100%	100%
17	100%	100%	100%	100%	100%	100%	75%	83%	71%	100%	100%	100%
18	100%	100%	100%	100%	100%	100%	59%	68%	64%	100%	100%	100%
19	100%	100%	100%	100%	100%	100%	63%	66%	56%	100%	100%	100%
20	100%	100%	100%	100%	100%	100%	64%	66%	59%	100%	100%	100%
21	100%	100%	100%	100%	100%	100%	75%	76%	73%	100%	100%	100%
22	100%	100%	100%	100%	100%	100%	85%	87%	84%	100%	100%	100%
23	100%	100%	100%	100%	100%	100%	85%	94%	88%	100%	100%	100%

STATUS QUO: Planning Limits for 3.8MW EV Charging Station

FLEX CONNECT: Can Support Full Request ~90% of the time on Average

Key Takeaway – If a customer can reduce consumption for 3 months during 3-11PM we can serve their full load request



Customer Journey for participation in Flexible Service Connection MVP

In 2024 PG&E will be working to standardize customer engagement and site evaluation processes based on initial learnings

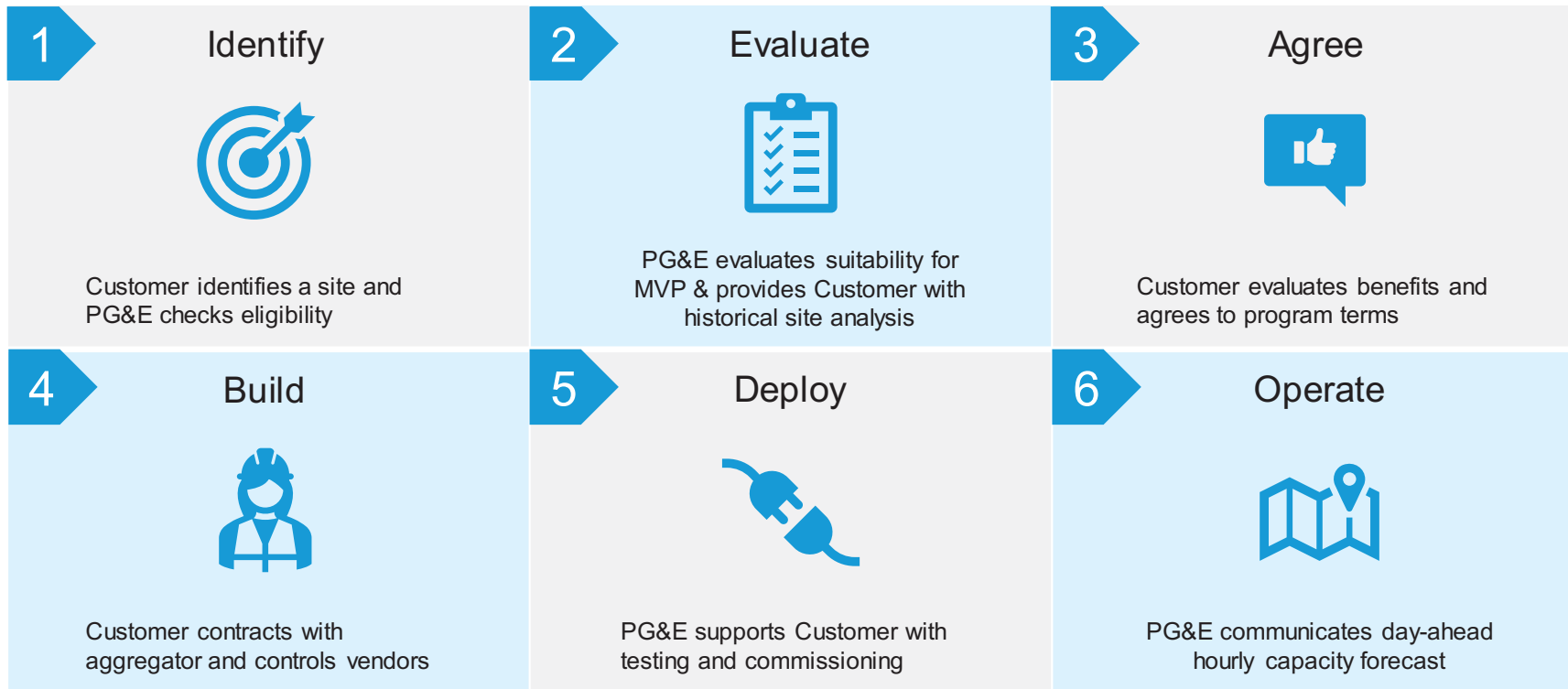



Flexible Service Connection Operations

24hr ahead DER customer import limits

Enabling customers with eligible loads to connect sooner by dynamically managing consumption based on grid availability

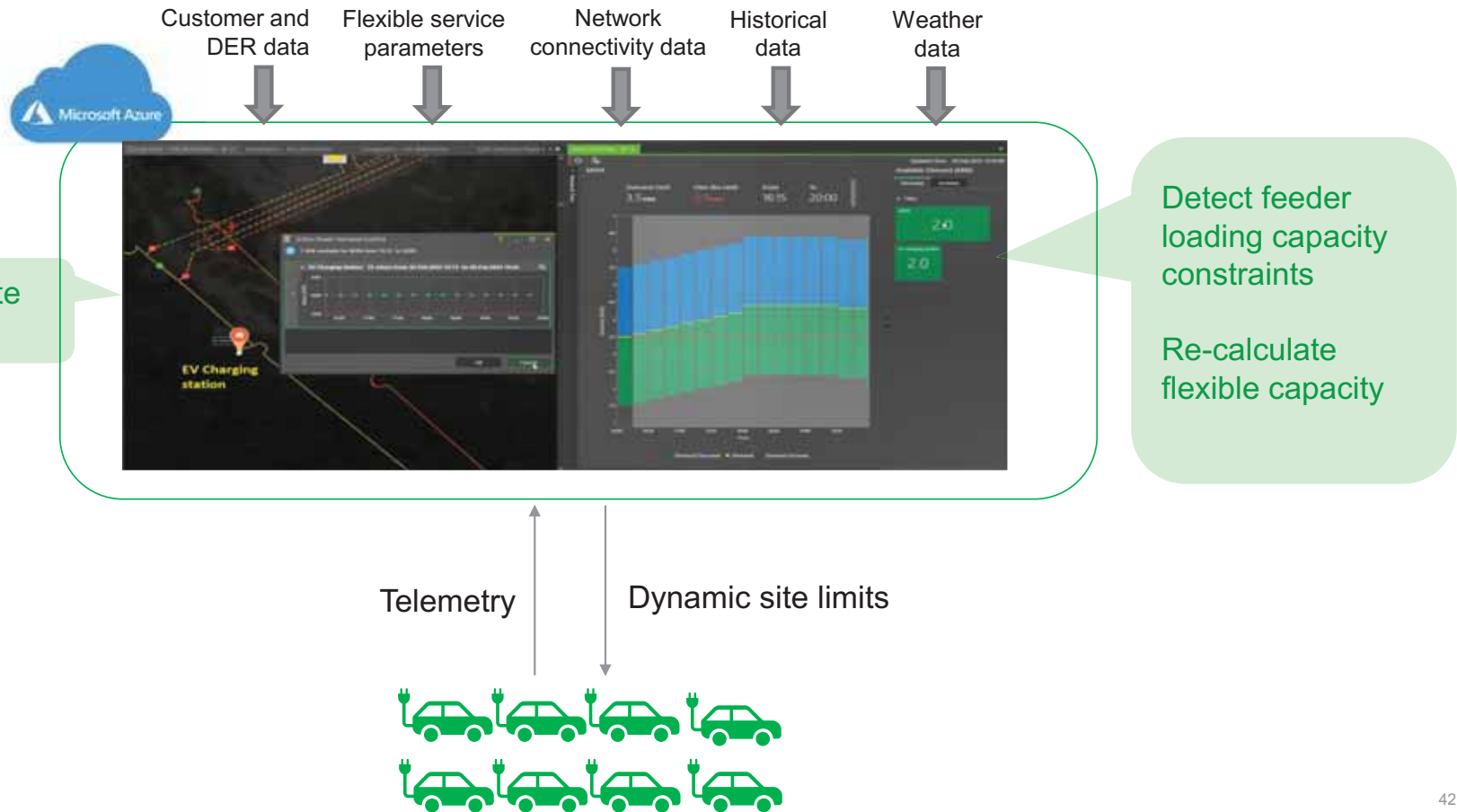



Illustrative Site Configuration

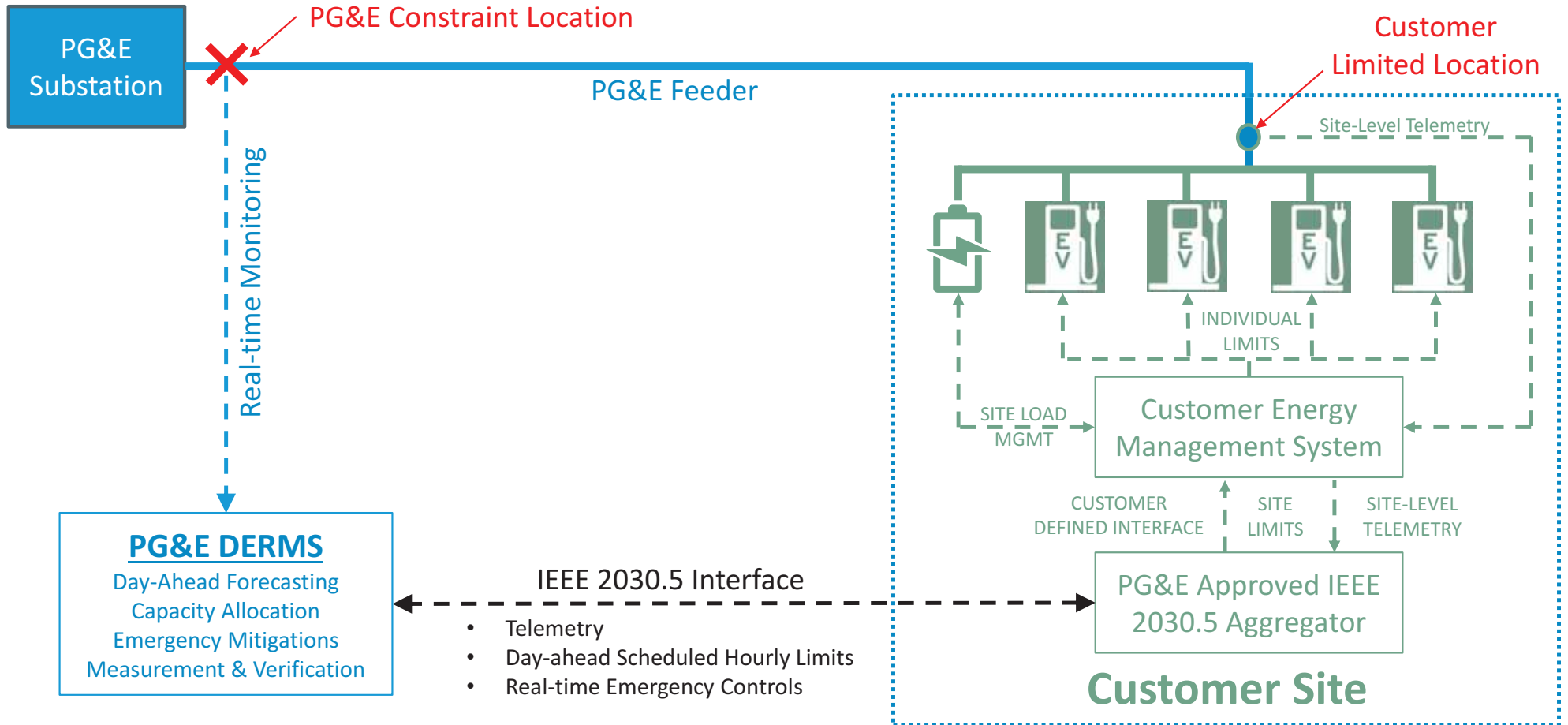

Agility is required to rapidly iterate toward a future end state

Capabilities, technology and processes are still being developed and require validation and further evaluation prior to scaling

Key Customer considerations:

- Value vs cost
- Customer experience impacts
- Local site technology readiness and timing
- Ability to adhere to dynamic limits

Key Utility considerations:

- PG&E technology and DERMS readiness – Forecasting, dispatching, and integrations with 3rd-party and internal systems
 - Key enhancements based on initial deployment already identified
 - Geographic expansion of DERMS capabilities
- Building confidence in customer-owned solutions and ensuring failsafes and contingencies
- Operational integration
- “Next-customer” considerations



Thank you

Neema Yazdi | Clean Energy Transportation, PG&E
Neema.Yazdi@pge.com

Alex Portilla | Grid Innovation, PG&E
Alex.Portilla@pge.com



Together, Building
a Better California

Vehicle Grid Integration Forum

Load Control Management Systems (LCMS)

VGI Forum – March 22, 2024

Roger Salas P.E., MSEE

Distribution System Analysis Principal Manager

Energy for What's Ahead™



Discussion Topics

- LCMS Use Case As Bridging Solution
- Challenges to Implement LCMS
- SCE LCMS pilot
- SCE Pilot Schedule
- Q/A

LCMS Use Case As Bridging Solution

Faster Service Energization

- Increased demand is causing capacity constraints in certain areas of the grid.
 - Many grid upgrades will take years 3+ years, which prompts utilities to start the planning and designing of grid upgrades much earlier than before.
- Much of new electrical demand is from flexible load systems (e.g., charging stations)
- While grid upgrades are completed, the service can be energized and allowed to consume electrical power as function of time (seasons, time of day) depending on customer control capability
- Allowing LCMS to support faster service energization will allow for maximum utilization of grid assets and good customer service while traditional infrastructure is built
- LCMS is highly depending on load profiles and will not be option in all cases

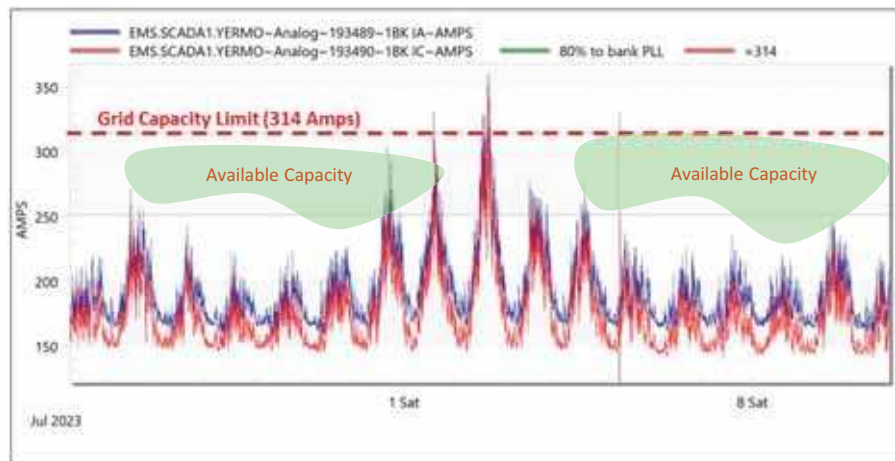

An LCMS can be used to allow the flexible load (e.g., charging station) to use more capacity outside the peak period

Challenges in Implementing LCMS

Technology Challenges

- There are no national standards for testing and certifying LCMS equipment
- SCE participating in development of UL3141. While the standard is developed, SCE will evaluate and accept LCMS for system that meet SCE's technical requirements. Not ideal for engineering efficiency but will do for now.



Operational Challenges:

- No established operating procedures for operating the grid when using LCMS technology
- SCE developed operational procedures
 - What actions are taken in real time if LCMS fails?
 - How are real time operations coordinated with facilities that employ LCMS control?



Legal/Regulatory Challenges

- Currently no established regulatory procedures to accept this type of technology in the planning and operation of the distribution system
- SCE filed and received CPUC approval to implement an LCMS and related LCMS agreement via Advice Letter 5138-E/E-A, which we are using for pilot participants



LCMS Pilot

SCE initiated an LCMS pilot project to test the operational capabilities and challenges associated with using LCMS

Localized Autonomous LCMS:

- Local Control Controls owned/operated by host customer
- SCE reviews technical documents and confirms operational performance (typically lab testing)
- Agreement execution and documentation process
- Operational performance monitored by SCE and alarming emails sent to customer for nonperformance



Communication-Based LCMS:

- Evaluate ability of SCE to send limits via communication using different intervals (day-ahead, real time, other intervals)
- Evaluate communication mechanism (direct vs cloud server/aggregator)
- Evaluate utilization/challenges of IEEE 2030.5 for load management and bi-directional communication
- Evaluate compliance to new settings sent via communications

SCE Pilot Details (Localized Autonomous LCMS)

Currently Being Deployed

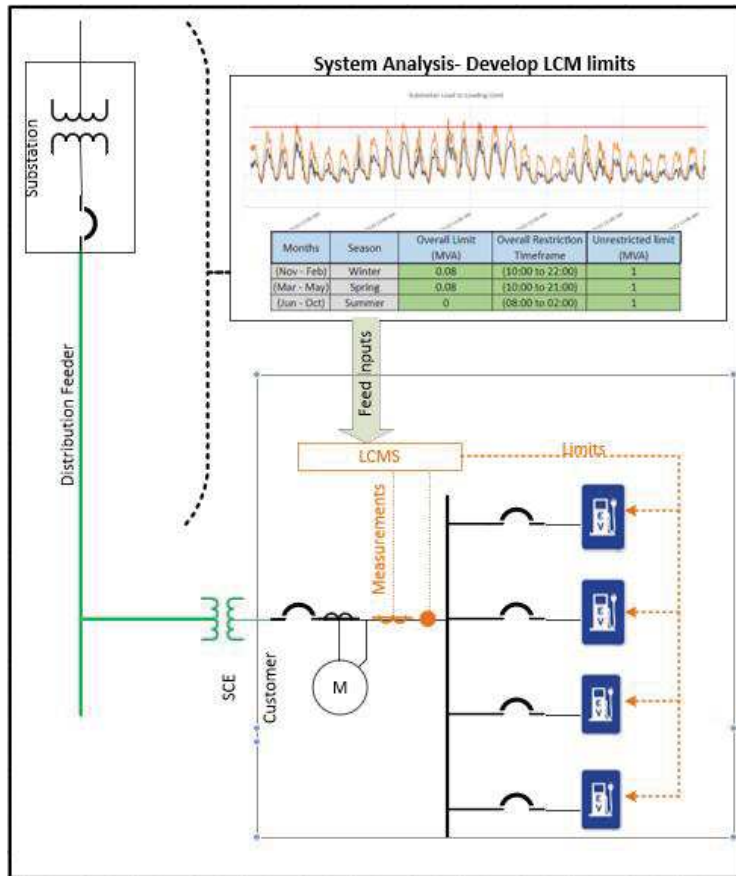

- SCE reviews technical specification and performance of the LCMS which may include lab or field performance verification
- SCE develops charging profiles based on of the following:
 - Flat value (limit on 8760 hours)
 - Season (summer, winter, etc.)
 - Time of day (9am-9pm; 9pm-9am)
- Customer executed LCMS agreement
- Customer programs the limits into the LCMS
- SCE monitors for performance and takes action as may be required

SCE Pilot Details (Communication-Based LCMS)

Discussing With Potential Pilot Participants

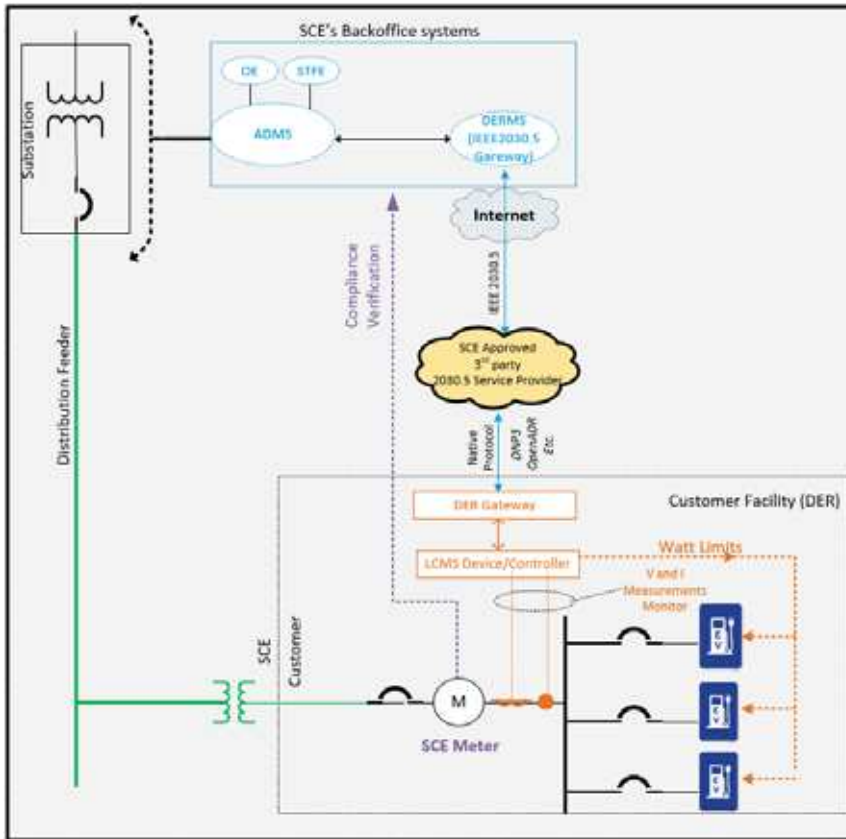

- SCE ADMS determine limits based on grid conditions, forecasting, and optimization .
- SCE DERMS sends limits to customer via IEEE2030.5 protocol through cloud-based interface protocol translator or directly to the facility communication interface
- Facility communications interface receives information and send to LCMS
- LCMS executes the limits
- The limits can be refreshed based on real-time, day-ahead, or other intervals
- LCMS communicated back to SCE on its performance
- SCE verifies performance via AMI data
- Action taken for nonperformance

SCE Pilot Specifications

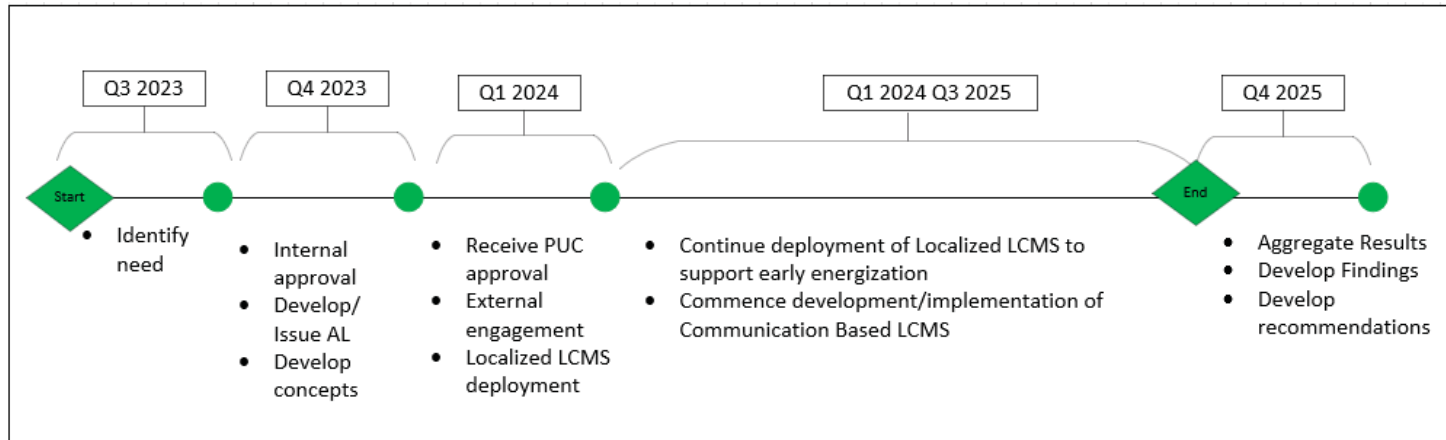

- 2-year pilot
- Open to all developers (EV or not)
- Participants must agree with the terms of the pilot
- Piloting both
 - Localized Autonomous LCMS
 - Communication-Based LCMS
- At the end of the two-year pilot, SCE will evaluate overall results and will recommend to make a permanent option or not to pursue for future use



Near-Term Solutions to Supporting VGI

March 22, 2024

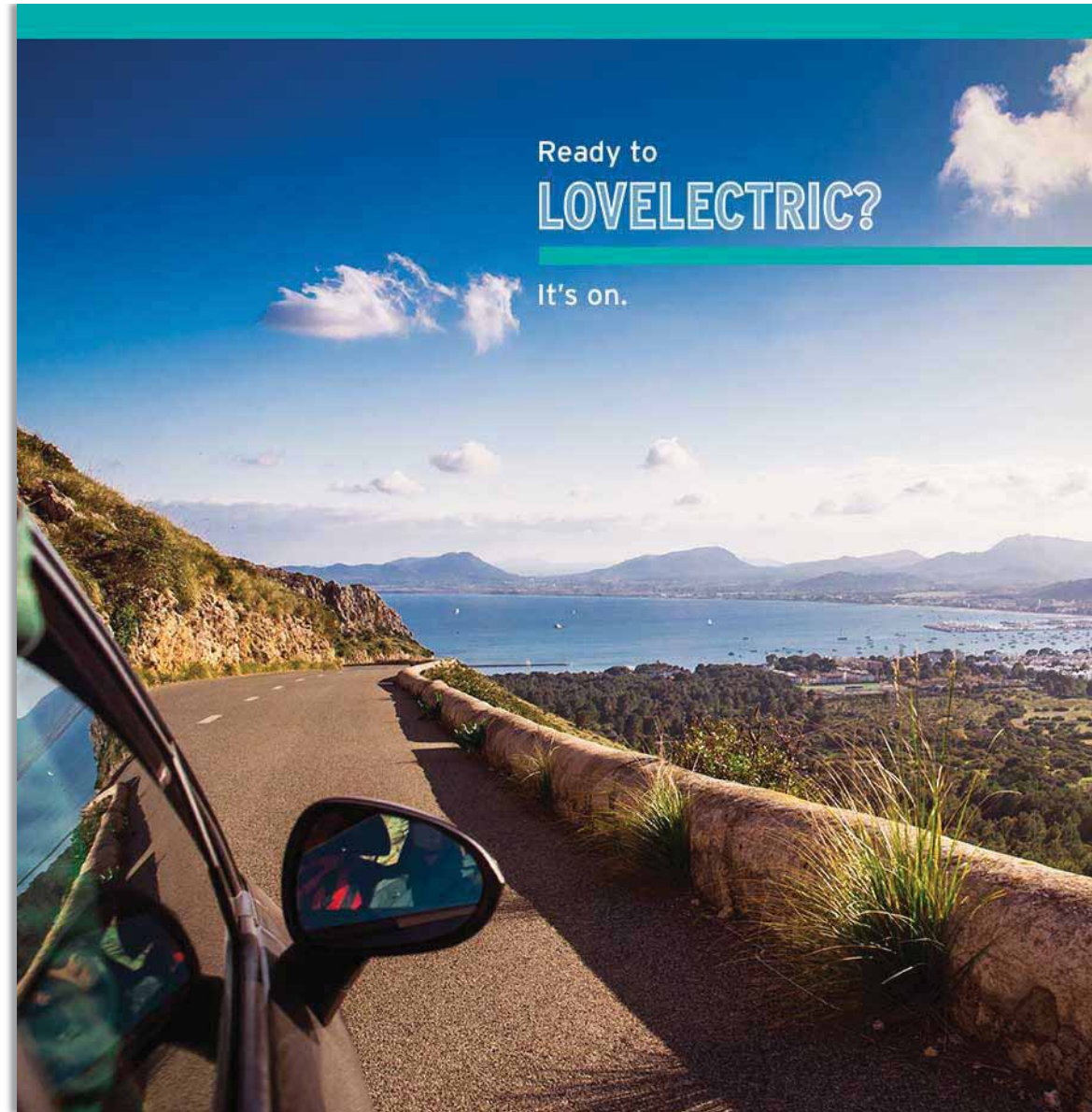

Part 2



Identifying Near-Term Solutions to Support Flexible/Scaled Service Agreements and Deployment of Supporting VGI Technology, including ALM

Objective:

- Identify technical or regulatory barriers associated with leveraging VGI technology to enable utilities to advance options for flexible/scaled service agreements
- Identify potential quick wins to address these barriers

Implementing Type I ALM

Today, many customers are implementing Type I ALM. While the site details vary, the concept is the same and can provide benefits to the customer and the utility.

Example	MUD customer installing 50 L2 charging stations, each rated at 50 amps or ~10 kw. Traditionally, SDG&E would plan for the full load (as if all ports could be turned on simultaneously) and would need capacity for 0.5 MW (50 ports @ 10 kw = 500 kw).
Solution	Customers install metering equipment with much smaller capacity (<i>e.g.</i> , 600 amps) and implementing Type I ALM behind the meter to throttle chargers or shift charging to different times so that the total load never exceeds the 600 amps capacity of the panel.

Mutual Benefits



Customer

- Difference in cost between a 600-amp meter pedestal and 2,500-amp switchgear is significant.
- The lead time to get the higher capacity switchgear is currently about a year. They can get a 600-amp meter pedestal in about 10 weeks.
- **Downside:** There are costs for that purchasing and installing ALM, and driver expectations might not be met if their charging is throttled, or their vehicle is not charged when expected.

Utility

- Matching the service and transformer size to 600-amp panel instead of 2,500-amp.
- Avoid bottlenecks and costs associated with grid upgrades.

Looking Forward



Barriers

- Lack of DERMS
- Communications and integration with grid operations
- Need for pilots, experience, learning
- Regulatory pathways



Opportunities

- Learn from other pilots
- Many vendors
- Technological advancements



Enabling standardized use of UL 3141- certified Power Control Systems (aka ALM) and Flexible Connection Agreements in IOU tariffs

CPUC VGI Forum

March 22, 2024

Barriers

- Power Import Limiting challenges the concept of “Obligation to Serve”
- PCS functionality is included in Rule 21, but not in Rules 2, 3, 15, 16, 29/45
 - SCE updated its Rule 16 to allow for ALM per its LCMS pilot
 - PG&E Rule 2, Sec. H. Connected Load Ratings cites nameplate ratings
- The lack of standardized tariff provisions, forms, T&Cs, limited import / export profile options, and technical product requirements inhibit uptake
 - Customers and developers have no awareness of offerings
 - Technology providers lack direction for product development
 - Utility service planners lack basis (or impetus) to study PCS setpoints

UL 3141

- New standard published January 2024 covering Power Control System functionality for loads and generation (taking over from UL 1741 PCS-CRD)
- First version includes test protocols for Power Export Limiting (PEL) and Power Import Limiting (PIL) at the **device level**, defined for energy storage (but also applicable to standalone EVSE loads behind a single meter)
- Second version is currently under development and will develop protocols for PIL at the **Point of Common Coupling (PCC)**, inclusive of controllable and non-controllable loads

Regulatory needs

- Develop clear language in IOU energization rules to recognize UL 3141-certified import limiting PCS as an alternative to connected load ratings (similar to language in Rule 21 for PEL) as part of a Flexible Connection agreement
 - Outcomes will help define (and refine) UL 3141
 - Precedent from Rule 21 and SIWG to adopt rules + requirements that don't go into effect until standards are ready
- Scope:
 - Define “firm,” “non-firm” service levels through lens of scheduling (e.g., # of hourly values + structure), operational needs, and customer agreements
 - Prioritize “autonomous functionality” (à la SIWG Phase 1), i.e., “out of the box” static PIL / PEL schedules that are programmed upon commissioning
 - Then consider operational flexibility that likely requires DERMS comms – what are criteria for throttling loads, and how is this effectuated?

Procedural Recommendations

- Build on SLOWG Report issued in February 2024 in Track 3 of the High DER Proceeding (R.21-06-017)
 - To the extent possible, must avoid bespoke implementation of the same concepts across the 3-4 relevant proceedings (EV, Energization, High DER, R21)
- New scoping memo in Track 3 to tee up revisions to IOU load rules to incorporate UL 3141, PCS, and optional Flexible Connections agreements
- Start with workshop, develop into SLOWG Phase 2 (?)

Enabling and scaling flexible connections

For EVs, small generation, controlled and uncontrolled loads

PIERO / Inaugural VGI Forum / 3-22-24



Two ALM/flexible connection implementations

	Static site limit (“ALM”)	Flexible connection
Method	<ul style="list-style-type: none"> Consistent, hard limit on aggregate kW usage 	<ul style="list-style-type: none"> Contractual agreement either for static limit or to temporarily curtail aggregate kW usage during predetermined periods
Intended impact	<ul style="list-style-type: none"> Site panel Overcurrent Protection devices on site 	<ul style="list-style-type: none"> Utility-side infrastructure Feeder/transformer/substation
Duration	<ul style="list-style-type: none"> Life of site Until electrified fleet increases 	<ul style="list-style-type: none"> Life of site Until utility-side infrastructure is upgraded
Communication	<ul style="list-style-type: none"> No external signal 	<ul style="list-style-type: none"> Notification, then trigger Text/Email Via smart meter API
Utility involvement	Notification-only with AHJ approval and appropriate certifications	Essential: utility determines limit based on infra constraints; may call curtailment events
Planning impact	Short term/upon energization request	Potential medium- to long-term infra planning & investment
Value	<ul style="list-style-type: none"> \$ Single customer time to energization 	<ul style="list-style-type: none"> \$\$\$ Multiple customers’ ability to energize at all

Standards ambiguity: CPUC can accelerate rollout by assessing and adopting UL 3141

- UL 3141
 - Builds and (and will replace) existing Power Control Systems guidance for inverters, previously attached to UL 1741
 - Enables various real-world VGI applications
 - EVs
 - Inverters
 - Controlled loads/inverters coordinating with uncontrolled loads
 - California Smart Inverter Working Group will host presentation in late April
- Various other standards have been considered or briefly accepted for EV load control, leading to confusion in industry
- Confirmed inappropriate by UL for EV load management when oversubscribing infrastructure
 - UL 916
 - UL 60730-1
- CSA SPE-343:21
 - Canadian standard, still in progress
 - EVs only

Regulatory development: Now vs Later (or at all)

- What is necessary to standardize and scale flexible connections?
 - What elements can be iterated and adjusted
 - Must be accessible to utilities of varying technical resources
 - Static vs dynamic limits; basic vs most advanced metering; temporary vs permanent limitations
 - What needs to be in place Day One
 - Contracts
 - Customer journey
 - Assessment criteria
 - What requires years of data
 - IRP/GRC impacts
- What needs worked out in a formal proceeding?
 - Site criteria for eligibility
 - Cost? Time? Inability to serve? Any time a utility-side upgrade is triggered?
 - Or is it up to the customer?
 - Study and report content
 - Study methodologies: some framework should exist while allowing for competition and innovation
 - Customer contract
 - What constitutes an “informed” customer who can make this choice
 - Who carries liability and risk?
- How do we allow innovation and competition while ensuring customer has predictable experience

Contact: jacqueline.piero@mobilityhouse.com





Process Improvements to Enable Mass-Market Limited/Scaled Service Connection

Zach Woogen

March 22, 2024 | VGI Forum



Vehicle-Grid Integration Council is exclusively focused on unlocking the value of flexible charging, V2X, and DER-paired charging

VGIC MEMBERS / 2024

LEADERSHIP CIRCLE MEMBERS

BORGWARNER

 **Fermata Energy**



HONDA

NISSAN
GROUP OF NORTH AMERICA

NUVE

GENERAL MEMBERS



emporía



FREEWIRE

Gridwiz



**Landis
Gyr+**



**PEAK
POWER**



qcells

STELLANTIS

ASSOCIATE MEMBERS



TOYOTA

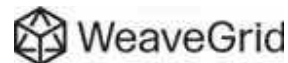

HOOSIERENERGY



VGIC

View the latest members at vgicouncil.org/about/members

Technologies to Support Limited/Scaled Service Connection

Software-Based Power Control
(e.g., workplace charging, multi-family homes, fleet depots)



1. Instead of each station operating at full power all the time, **stations are controlled individually** based on charging demand.
2. This allows **more charging stations** to be installed while only using a fraction of the aggregate power traditionally required.
3. Businesses shave as much as **60% off** the cost of electrical system upgrades and peak demand charges.

Source: PowerFlex / EDF Renewables

Integrated or Co-Located Energy Storage
(e.g., fleet depots, public DC fast chargers)



Source: FreeWire Technologies, Inc.



OUTPUT POWER	Any combination of OCPP compliant EV chargers and other loads up to 240 kW
INPUT POWER	10 kW to 165 kW for each VPort

Source: Veloce Energy

Re: SCE's LCMS Pilot

SCE AL 5138-E: *"Includes both localized autonomous LCMS and communications-based LCMS:*

- **Localized Autonomous LCMS:** *uses a programmed limit, operates autonomously to locally control flexible loads to maintain the power import level to the programmed limit without external communications; can be programmed locally or remotely via communications*
 - **Communications-based LCMS:** *limits received from SCE via "communications." cloud-based services or directly to the load customer facility by an SCE-approved comms gateway"*
- In the near-term, localized autonomous LCMS is likely most feasible and suitable for EV charging use cases, which rely on some level of predictability (i.e., pre-determined setpoint) to support charging needs

Why now?

- Several recent policy and market drivers place limited/scaled service connection center stage:
 - ACC II, ACF, ACT, and overall pace of EV deployment in the face of existing distribution grid constraints
 - California's Limited Generation Profile Implementation
 - California's Smart Inverter Operationalization Working Group Report
 - High DER OIR Staff Proposal
 - SCE's LCMS Pilot & PG&E's Flexible Service Connection Pilot
 - CA's new TE OIR and new Energization Timelines OIR
 - NY's Load Management Technology Incentive Programs & MA's Automated Load Management Implementation
 - Publication of UL 3141 and upcoming revision

Potential Design Elements for Limited/Scaled Service Connection Framework

- **Customer choice:** Must be a customer choice, e.g., to wait for upgrade vs limited/scaled service connection.
- **Marketing, education, and outreach:** Customers need information on options available to them and the implications of their decision.
- **Customer enablement tools:** Customers and developers need tools to interact with utilities that enable limited/scaled service connection. This may include pro-forma applications, more accurate/real-time hosting capacity maps, etc.
- **Site and tech requirements:** Vendors need clear rules and requirements. Consistency and shared technical requirements across utilities may be most scalable.
- **Public reporting:** Stakeholders need clear and consistent data collected to support future program and/or rule revisions.
- **Impact on grid planning:** Load must be assessed dynamically, rather than statically, and incorporated into utility planning as such.

Key Questions

- Who “initiates” limited/scaled service connection discussion/election?
 - Does the utility assess the site and support customers in finding technologies?
 - Does the customer work with the vendor to incorporate tech before submitting energization request?
- What tools are needed to operationalize limited/scaled service connection?
 - E.g., pro-forma application with fields identifying (a) technology to be used (e.g., UL 3141 software, integrated storage, localized autonomous control, communications-based control, etc.), (b) kW power limit, (c) timeline for scaling service limit
 - E.g., accurate, up-to-date hosting capacity maps
- What incentives or shared savings models may be needed to accelerate the use of enabling technologies?
 - E.g., program-scale benefit-cost analysis vs site-specific avoided costs

Potential Discrete (or Co-Existing) Models for Initiating Limited/Scaled Connect

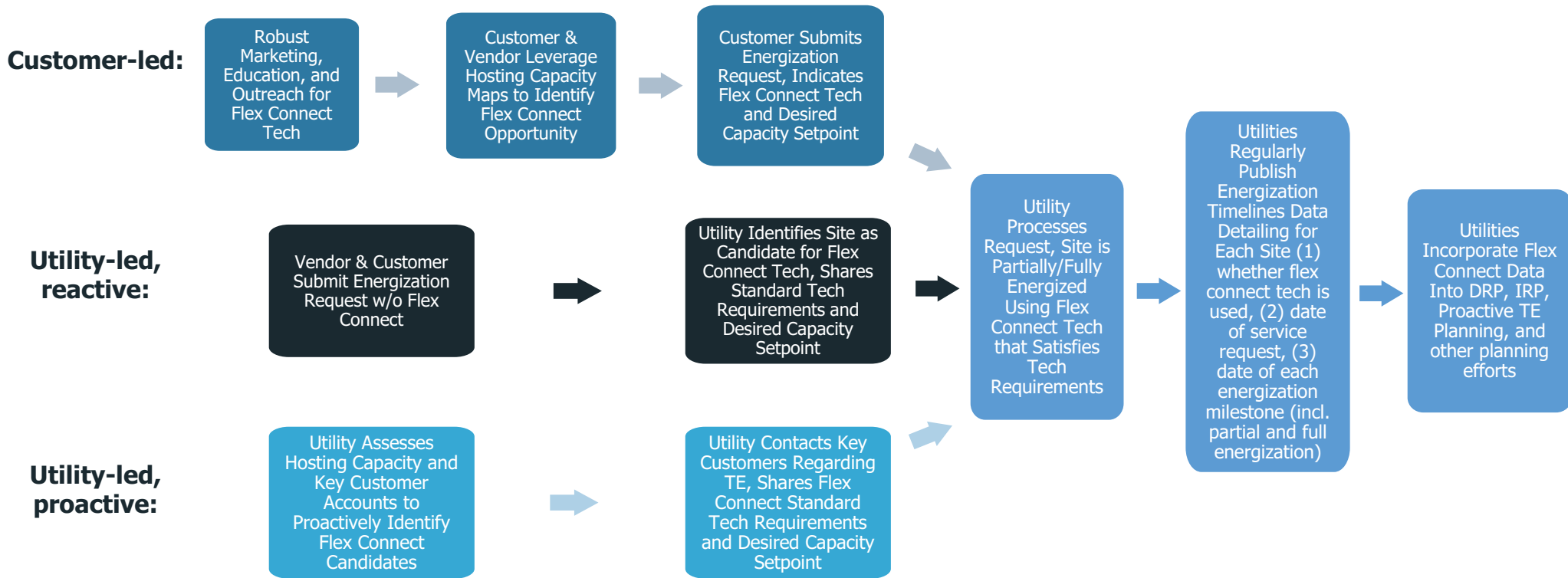

Thank you!

Vehicle Grid Integration Council (VGIC) is a national 501(c)(6) membership-based trade association committed to advancing the role of electric vehicles and vehicle-grid integration through policy development, education, outreach, and research.



Identifying Future Procedural Priorities and Topics for Future VGI Forums

Objective:

- Identify additional needed action on VGI priorities including discussion of interconnection and VGI, which could be addressed later in other proceedings as appropriate such as the TE Policy (R.23-12-008) and Infrastructure proceeding.
- Allow industry to discuss perceived challenges and barriers to connection of EVSE and VGI technologies to the grid (including energization and interconnection).

Where we are today



SOUTHERN CALIFORNIA
EDISON[®]



DRIVE OIR

- Working Group
- Integration Strategies
- Pathways for ongoing conversations around VGI advancement
- LCFS holdback

Interconnection

- V2G DC EVSE enablement
- UL Power Control Systems CRD
- V2G AC pilot pathways
- CEC V2G Equipment List

VGI Projects

- ELRP
- Dynamic export rates
- ALM
- EPIC projects
- VGI Pilots

LOVELECTRIC

Priorities and Regulatory Action Needed



Streamlined
approval

Compensation
Mechanisms

Technology &
Standards

Interconnection

Customer
Experience

Priorities and Regulatory Action Needed



Priorities

- Standards and interoperability
- Pilots and lessons-learned
- Clear ecosystem roles and responsibilities
- Integration of new technologies
- Targeted use cases and scaling

Regulatory Action

- Narrow, targeted scope for VGI in new proceeding
- Collaboration with industry to problem-solve around technical gaps and barriers
- Streamlined regulatory pathways to pursue pilots and programs for VGI initiatives
- Ability to appropriately compensate participants



Park It. Plug It. Profit.

Inaugural VGI Form: Part 3 Panel #2—Emerging Issues in Interconnection/Energization

Anna Bella Korbatov
Director of Regulatory Affairs

March 22, 2024



Fermata Energy V2X Product + Services Ecosystem

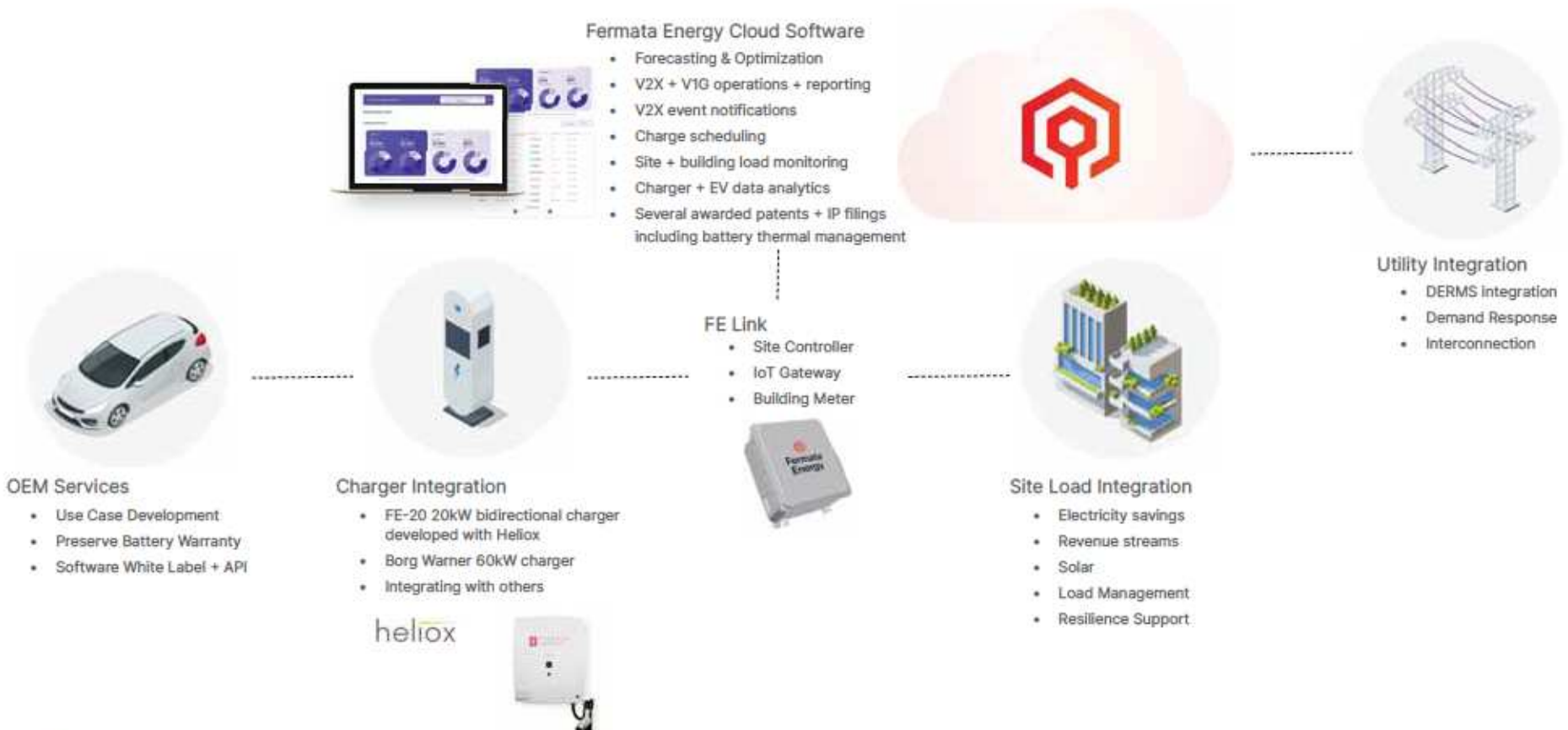

Rhode Island municipal deployment earns **\$12,500+**

When: Summers 2021, 2022, & 2023

What: Vehicle-to-grid (V2G) demand response using Fermata Energy's V2X bidirectional charging platform

EV Earned: \$12,553 with 1 EV and 1 Fermata Energy V2G bidirectional charging platform

Where: Municipal wastewater treatment facility

Program: Rhode Island Energy - "Connected Solutions."
Discharging energy in an EV battery back to the grid at times of peak grid demand, during 2-3 hour long events in late afternoon.



"These results help to give us confidence that **electric vehicles can be a reliable partner in providing a clean and resilient electricity grid** for the future," said John Isberg, Vice President of Customer Sales and Solutions at National Grid (now a Rhode Island Energy project).

CEC Grant 22-612: ESB Bidirectional Infrastructure

When: Q1 2025

What: 2.5 MW V2G deployment

\$3 million grant to deploy 21 BorgWarner 125 kW bidirectional chargers + 20 LionD electric school buses + Fermata energy V2X software

Where: Long Beach & Thousand Oaks High School

Programs: ELRP, SCE Dynamic Rate Pilot

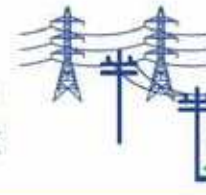

BORGWARNER

⚡ LION ELECTRIC

 Fermata Energy

 AMERICAN
TRANSPORTATION

"With this new technology, electric school buses are not only delivering cleaner air to our children and cost savings to our school districts, but also providing extra power to the grid when we need it most," said Patty Monahan, California Energy Commission's Lead Commissioner for Transportation.

V2G DEPLOYMENTS | FERMATA ENERGY

V2G Interconnection Experience

Interconnected chargers BTM, separately metered, for microgrid projects and for a variety of use cases, including:

- Demand Response
- Demand Charge Management
- Frequency Regulation
- Microgrid Testbeds
- Dynamic Rates

Interconnected and operating 30+ V2X sites

Worked with 21 utilities across 17 states and 2 countries to interconnect customer V2X sites

- CA, CO, CT, FL, GA, KY, MA, MI, NC, NH, NY, PA, TN, TX, RI, VA, VT, British Columbia, Nova Scotia

Verified V2G operations with

- Utilities
- Federal government
- Municipalities
- Private deployments
- Automotive manufacturers



Fleet site operating

V2G earning for customers



Fleet site in development



Utility site operating



Utility site in development

Lessons Learned & Best Practices from Around the Country

- **Appropriate size thresholds** for “small generator or stationary storage” interconnections for relatively small V2X EVSE (e.g., 15kW and 20kW)
- **Timely, clear communication and explanation of the process flow and timelines for review**
- **Dispute resolution process** should be used to mediate disputes via a third-party (i.e., other than the public utilities commission).
- **V2X-specific commissioning tests, instead of requiring solar commissioning tests** that are not applicable to batteries or V2X
- Utilities often do not know whether V2X should be considered under the **BESS or EV interconnection process**
- **Interconnection pre-application reports to assess hosting capacity**

Quick Wins for CPUC and IOUs on V2G DC Interconnection

Interconnection exemptions for **DEBA GFO, DSGS, and SDG&E Dynamic Rate Pilot** to enable interconnection of V2G DC EVSE not certified to UL 1741-SA or SB

Interconnection exemptions already exist for ELRP and SCE and PG&E Dynamic Export Rate Pilots

Clarify purpose of **CEC V2G Equipment List**



How can the CEC V2G EL help IOUs and VGI industry?

Reduce **\$800 interconnection fee** per application, especially for DAC customers

Interconnection fees in CA are 2-8X that of 1x fees in other parts of the country

Longer-Term Action on V2G Interconnection

Improved IOU hosting capacity maps and tools to assist in project planning and site design

Build internal capacity to prepare for high volume of Ix apps; streamline and automate parts of app process

Consideration of flexible interconnection / limited generation profiles to speed up interconnection of V2G projects

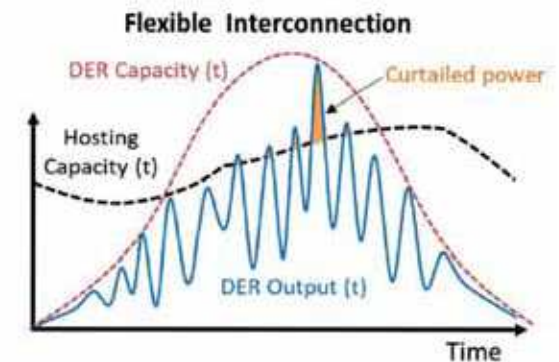

Opportunities to Scale Bidirectional Charging

Parity with Stationary Storage

- incentive programs comparable to those for stationary storage (e.g. SGIP-like); upfront and performance-based incentives
- integrate V2X in utility planning processes
- allow V2X to value stack and dual participate in rates/programs



Make-Ready and EV Charging Infrastructure Funding Access

- access for bidirectional chargers to utility make-ready funding opportunities on par with V1G EVSE
- technology-neutral rebates for V2G chargers and associated equipment



Newly convened TE-OIR (R.23.12.008) is the right venue for addressing both of these barriers to the scale adoption of V2X

Conclusions

For V2X to Scale in CA:

- V2X needs to be fundamental to TE planning, not an afterthought
- Need to ensure interconnection is not a barrier
- V2X ALSO needs supportive policies to scale
 - Access to upfront incentives and performance-based incentives on par with stationary storage
 - Ensure access to infrastructure funding on par with V1G

Thank you.

For more information, please visit

www.fermataenergy.com

or contact

Anna Bella Korbatov - Director of Regulatory Affairs

annabella@fermataenergy.com





Powering the grid transition



Our Vision

Accelerating
the transition to the
clean electric grid
by providing local,
scalable, fuel-flexible
power

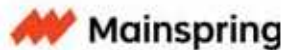

Local, scalable, fuel-flexible power

Commercial Behind-the-Meter



Zero-Carbon Grid-Scale Capacity



Rendering of 9 MW ammonia storage project

Mainspring powers with and without grid power

Grid ON

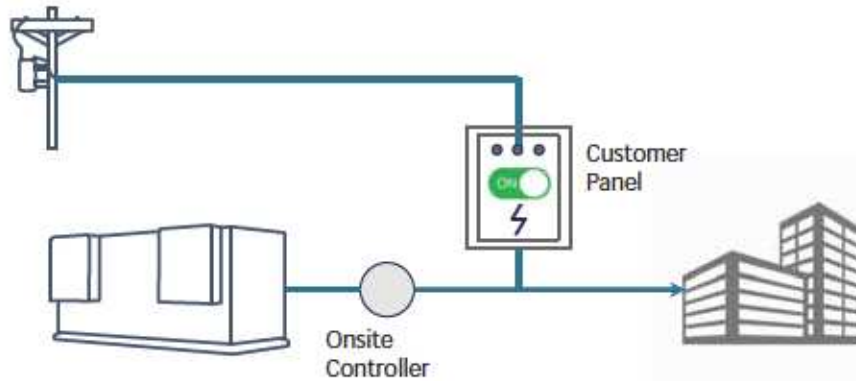

Grid-parallel operation typically means one of the two following modes, though there is flexibility if needed:

- Prime mode: Minimize power draw from grid at all times
- Peak shaving mode: Minimize power draw from grid during highest priced hours as defined by the utility tariff



Capable of accepting full load from grid-parallel or standby in 10 seconds

Grid OFF

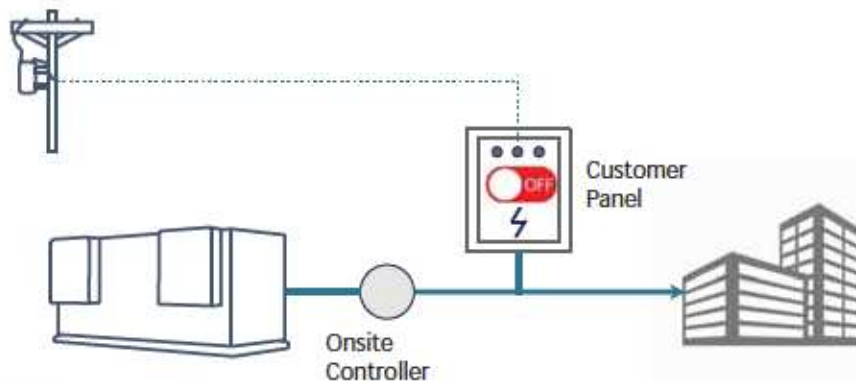

Grid-forming/islanded operation provides power when the grid is down and can seamlessly transfer back to grid-parallel.

- Requires additional onsite equipment (e.g., transfer switch)
- 250 kVA continuous and 300 kVA for 10 seconds (limited by inverter capabilities)

A clear pathway to zero or negative emissions

CO2 Emissions in metric tons per 100 miles driven

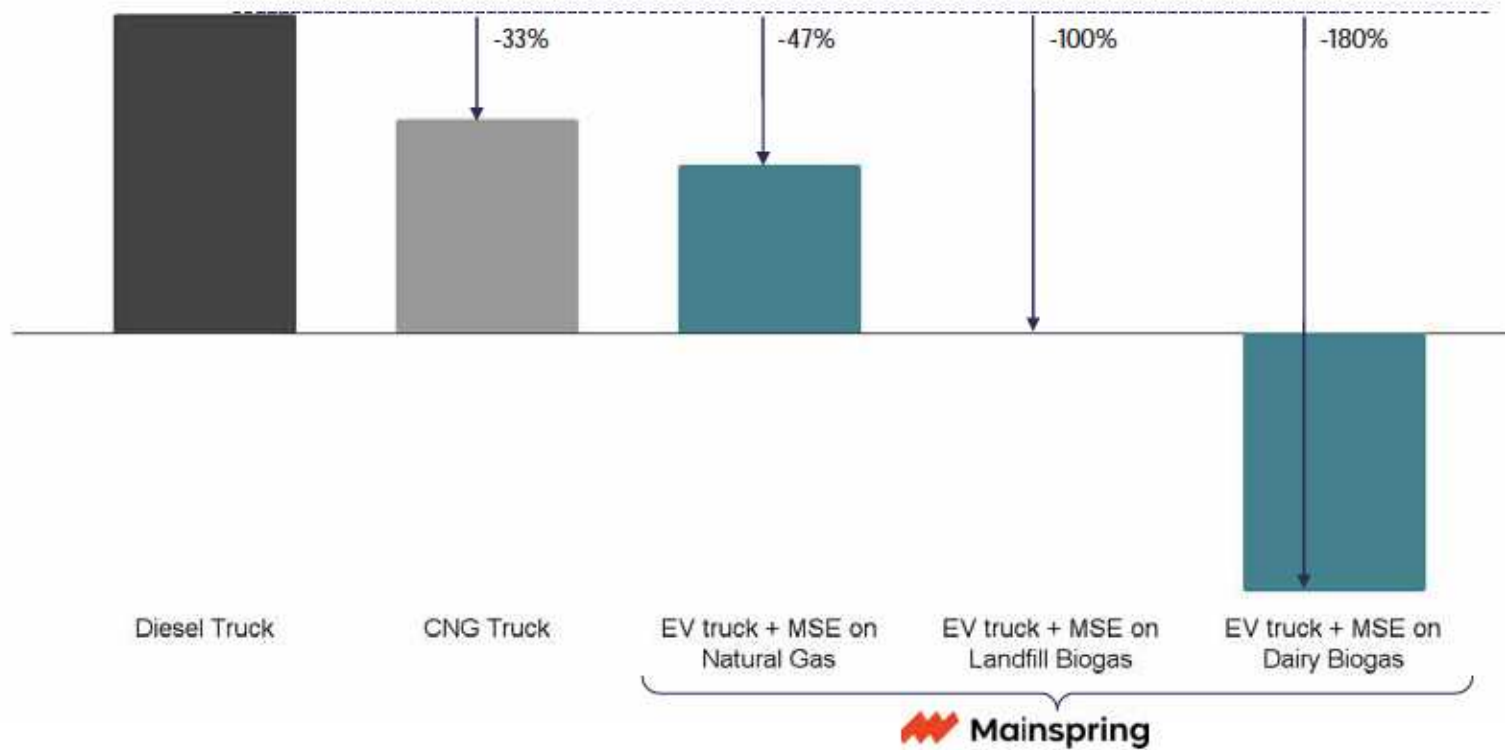

Assumptions: EV truck efficiency 2.2 kWh / mile, charger efficiency 94%, diesel truck mileage 4.9 mpg, CNG truck mileage 5.3 mpg diesel equ.

Clean, onsite EV fleet charging



- Speeds power build-out for EV expansion
- Builds local resilience
- Incentivizes investment in EV fleets
- Fuel-flexibility reduces risk
- Local installations reduce grid congestion

Mainspring delivers Prologis cost savings over traditional generators AND a path to clean fuel alternatives while shrinking the time to power from more than 2 years to 8 months.

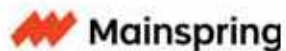

Rendering of 9 MW truck fleet EV charging microgrid

V2X Adoption: Customer Installation and Interconnection Barriers

Vehicle-Grid Integration (VGI) Forum

March 22, 2024

Michelle Bogen

Project Manager, Grid Services



Value Beyond Mobility



Intelligent Backup Power (IBP)

What is it?

- Ford F-150 Lightning – All-electric light-duty truck with bidirectional charging capabilities
- IBP System includes 3 distinct components
 - 1) Vehicle, 2) Ford Charge Station Pro, and 3) Home Integration System (includes Microgrid Interconnection Device, inverter and dark-start battery)
 - During a grid outage, the system disconnects & isolates from the grid
- Definitions within Automotive/Ford
 - **Backup Power:** Operates like a backup fossil fuel generator with a transfer switch
 - **V2H:** Grid-connected, bi-directional charging with zero net export across the main electrical meter
 - **V2G:** Grid-connected, bi-directional charging with export across the main electrical meter

B. ISLANDED (FOR BACKUP)



No generator interconnection and little-to-no review required (e.g., notification-only, similar to fossil fuel backup generator)

C. PARALLEL, NON-EXPORT (discharge < site load)



Can fit within existing non-exporting small generator interconnection frameworks

D. PARALLEL, EXPORT (discharge > site load)

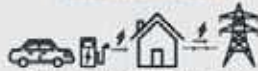

Can fit within existing exporting small generator interconnection frameworks



Collaboration with PG&E

Lessons Learned

- **Installation complexity**
- **High-variability in costs**
- **Need for more customer education, and**
- **Incentive programs that consider high-variability in existing home conditions.**



PG&E and Ford Accelerating Vehicle-to-Home Technology in California

PG&E and Ford Motor Company today announced that the all-electric Ford F-150 Lightning (model years 2022 or 2023) paired with Ford Charge Station Pro & Home Integration System has been approved as the first equipment set eligible for participation in PG&E's residential Vehicle-to-Everything pilot.

Intelligent Backup Power Early Install Project

- 2 PG&E employees
- Goals: run through end-to-end installation process with Ford, PG&E and Sunrun teams
- Witness testing/demonstration with PG&E's interconnection engineers

Participation in PG&E's Residential V2X Pilot

- Ford F-150 Lightning was 1st eligible vehicle
- Phase 1 – backup power testing (currently, a few enrolled customers)
- Phase 2 – grid-connected, bidirectional charging that follows real-time, day-ahead signals

Collaboration between utilities, OEMs and installers is key to learning how to improve processes and make bidirectional EV technologies ubiquitous and simple for customers to adopt.

Customer Barriers to V2X Adoption

Best Practices & Recommendations

Installation

- Complexity
- Lack of customer knowledge & education
- Cost variability

Interconnection

- Uncertainty around what "types" of bidirectional EV technologies require interconnection
 - Causes installation delays and frustration from customers
- Uncertainty around the interconnection process itself
 - At the state-level, ensure current rules are clear
 - Easy process to transition between different "modes"
- Streamlined incentive program across the state to help reduce costs for early adopters



Key Takeaways

Avoid reinventing the wheel.

V2X systems can fit within existing processes.

Minimize unnecessary review.

Load-only and islanded systems should require little-to-no interconnection review.

Provide customers with flexible options.

Systems initially used in load-only or islanded modes should be permitted to seek grid-parallel interconnection at a later date.

Ford